

PART NUMBER	REV	FIRST USED
671421-2	AA	1-471273-3

TERMINAL NAME: LENGTHWISE AMPLIVAR THRU SPLICE	CRIMPING DATA		
1500-5000 CMA	CRIMP HEIGHT	WIRE SIZE	CMA
41765	.075	(1)#18 MAGNET &	3400
41899		(1)#18 STRANDED	
42083			
42119			
600-3000 CMA			
42076	CRIMP	SIZE	TYPE
42192	WIRE	.110	F
485009	INSUL	-	-
170152	FEED	APPL INST	SET UP GAGE
1217384	.270	-	-
TERM APPL SPEC 114-2009	WIRE STRIP LENGTH	.279-.341	

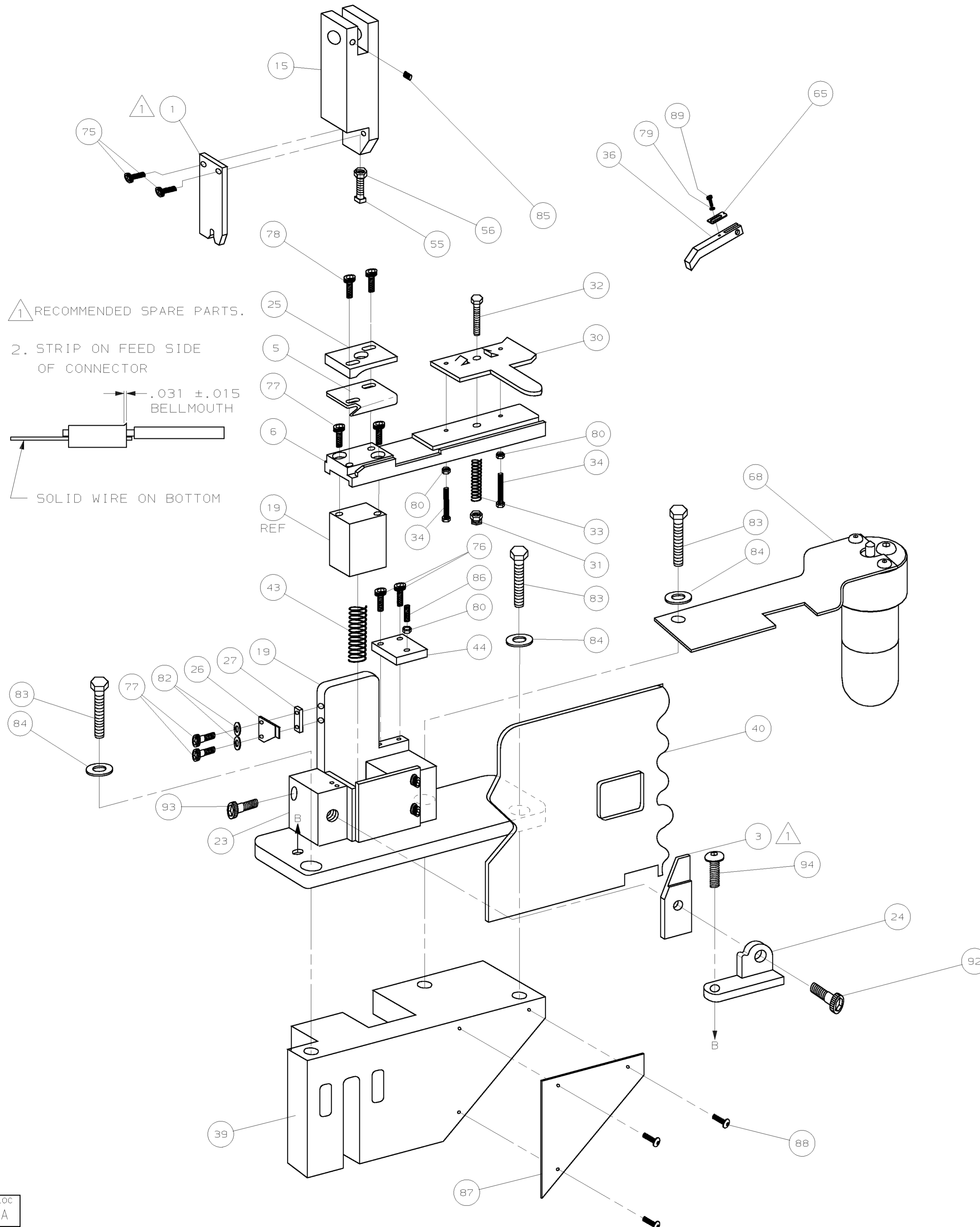

-	-	-	-	129	
-	-	-	-	128	
-	-	-	-	127	
-	-	-	-	126	
-	-	-	-	125	
-	-	-	-	124	
-	-	-	-	123	
-	-	-	-	122	
-	-	-	-	121	
-	-	-	-	120	
-	-	-	-	119	
-	-	-	-	118	
-	-	-	-	117	
-	-	-	-	116	
-	-	-	-	115	
-	-	-	-	114	
-	-	-	-	113	
-	-	-	-	112	
-	-	-	-	111	
-	-	-	-	110	
-	-	-	-	109	
-	-	-	-	108	
-	-	-	-	107	
-	-	-	-	106	
-	-	-	-	105	
-	-	-	-	104	
-	-	-	-	103	
-	-	-	-	102	
-	-	-	-	101	
-	-	-	-	100	
-	-	-	-	99	
-	-	-	-	98	
-	-	-	-	97	
-	-	-	-	96	
-	-	-	-	95	
1	-	A	1-21001-7	SCR, SHC, 5/16-18 X .62	94
1	-	A	3-21001-4	SCR, SHC, 3/8-16 X .88	93
1	-	A	21001-5	SCR, SHC, 1/4-20 X .88	92
-	-	-	-	-	91
-	-	-	-	-	90
1	-	A	2-21000-5	SCR, SHC, 8-32 X .25	89
3	-	A	21017-6	SCREW, DRIVE	88
1	-	B	452373-1	PLATE, ID	87
1	-	A	3-21000-9	SCR, SHC, 10-32 X 1.00	86
1	-	A	2-21549-3	SCR, SOC SET, 1/4-20 X .25	85
3	-	A	371178	WASHER, FLAT, 3/8	84
3	-	A	3-21015-2	SCR, HEX HD, 3/8-16 X 1.25	83
2	-	A	21055-7	WASHER, FLAT, 1/4	82
-	-	-	-	-	81
3	-	A	21018-7	NUT, HEX 10-32	80
1	-	A	21055-6	WASHER, FLAT, #8	79
2	-	A	3-21000-7	SCR, SHC, 10-32 X .75	78
4	-	A	3-21000-6	SCR, SHC, 10-32 X .62	77
2	-	A	3-21000-4	SCR, SHC, 10-32 X .38	76
2	-	A	21001-2	SCR, SHC, 1/4-20 X .62	75
-	-	-	-	-	74
-2	U/M	DWG SIZE	PART NO	DESCRIPTION	ITEM NO
-	-	-	-	REVISION OF EACH ASSY NO (WHEN BLANK, USE DWG REVISION)	-

-	-	-	-	-	73
-	-	-	-	-	72
-	-	-	-	-	71
-	-	-	-	-	70
-	-	-	-	-	69
-	-	-	-	-	68
1	-	-	465184-2	LUBRICATOR ASSY	67
-	-	-	-	-	66
1	-	A	374999	TENSION ADJ PLATE	65
-	-	-	-	-	64
-	-	-	-	-	63
-	-	-	-	-	62
-	-	-	-	-	61
-	-	-	-	-	60
-	-	-	-	-	59
-	-	-	-	-	58
-	-	-	-	-	57
1	-	-	22202-1	NUT, HEX JAM, 1/4-20	56
1	-	-	21077-7	SCR, 50 HD SET, 1/4-20 X 1.50	55
-	-	-	-	-	54
-	-	-	-	-	53
-	-	-	-	-	52
-	-	-	-	-	51
-	-	-	-	-	50
-	-	-	-	-	49
-	-	-	-	-	48
-	-	-	-	-	47
-	-	-	-	-	46
-	-	-	-	-	45
1	-	-	372998	RETAINER, FEED PLATE	44
1	-	A	2-24017-7	SPRING SLIDE	43
-	-	-	-	-	42
-	-	-	-	-	41
1	-	-	460582-1	GUARD	40
1	-	C	570238	BASE CASTING	39
-	-	-	-	-	38
-	-	-	-	-	37
1	-	-	452817-1	FEED FINGER	36
-	-	-	-	-	35
2	-	A	372997	ADJ. SCREW, STOCK DRAG	34
1	-	A	23846-7	SPRING, STOCK DRAG	33
1	-	-	21015-8	STUD, STOCK DRAG	32
1	-	A	21022-4	NUT, STOCK DRAG HANDLE	31
1	-	-	372990	STOCK DRAG	30
-	-	-	-	-	29
-	-	-	-	-	28
1	-	-	379011	SPACER, CLEANER	27
1	-	-	810995-2	STRIPPER	26
1	-	-	376945	WIRE GUIDE	25
1	-	-	378975	AUX. ANVIL HOLDER	24
1	-	-	374348	ANVIL HOLDER	23
-	-	-	-	-	22
-	-	-	-	-	21
-	-	-	-	-	20
1	-	C	473933	APPLICATOR MOUNT ASSY	19
-	-	-	-	-	18
-	-	-	-	-	17
-	-	-	-	-	16
1	-	B	471057	RAM	15
-	-	-	-	-	14
-	-	-	-	-	13
-	-	-	-	-	12
-	-	-	-	-	11
-	-	-	-	-	10
-	-	-	-	-	9
-	-	-	-	-	8
-	-	-	-	-	7
1	-	A	373158	PLATE, FEED	6
1	-	B	387007	BLADE, SHEAR	5
-	-	-	-	-	4
1	-	B	385646	ANVIL	3
-	-	-	-	-	2
1	-	C	1-453919-5	CRIMPER, WIRE	1

THIS DRAWING IS A CONTROLLED DOCUMENT.

THIS DRAWING IS UNCLASSIFIED DATE 09-28-1995 BY AMP INCORPORATED. ALL RIGHTS RESERVED.

LOC A DIST 4

QTY RECD PER ASSY PARTS LIST

DIMENSIONS IN INCHES. DO NOT SCALE PRINT. TOLERANCES UNLESS OTHERWISE SPECIFIED:

2 PLC DEC ±
3 PLC DEC ±
4 PLC DEC ±
ANGLES ±
SURF TEXTURE: ✓
REMOVE BURRS, BREAK SHARP EDGES R.015 MAX

SCALE 1:4 DWG NO 671421-2

DR 5/17/93 APP 2-15-94
R. LEHR/UTA B WOLFE
CHK 2-15-94 REL 3/10/94
C ERISMAN B. MORGAN

AMP AMP Incorporated Harrisburg, PA 17105-3608

NAME END FEED STANDARD APPLICATOR MACHINE REF STD APPL
SCALE 1:4 DWG NO 671421-2 SHEET 1 OF 1 REV AA

CAGE CODE 00779 CUSTOMER AND ASSEMBLY DRAWING