

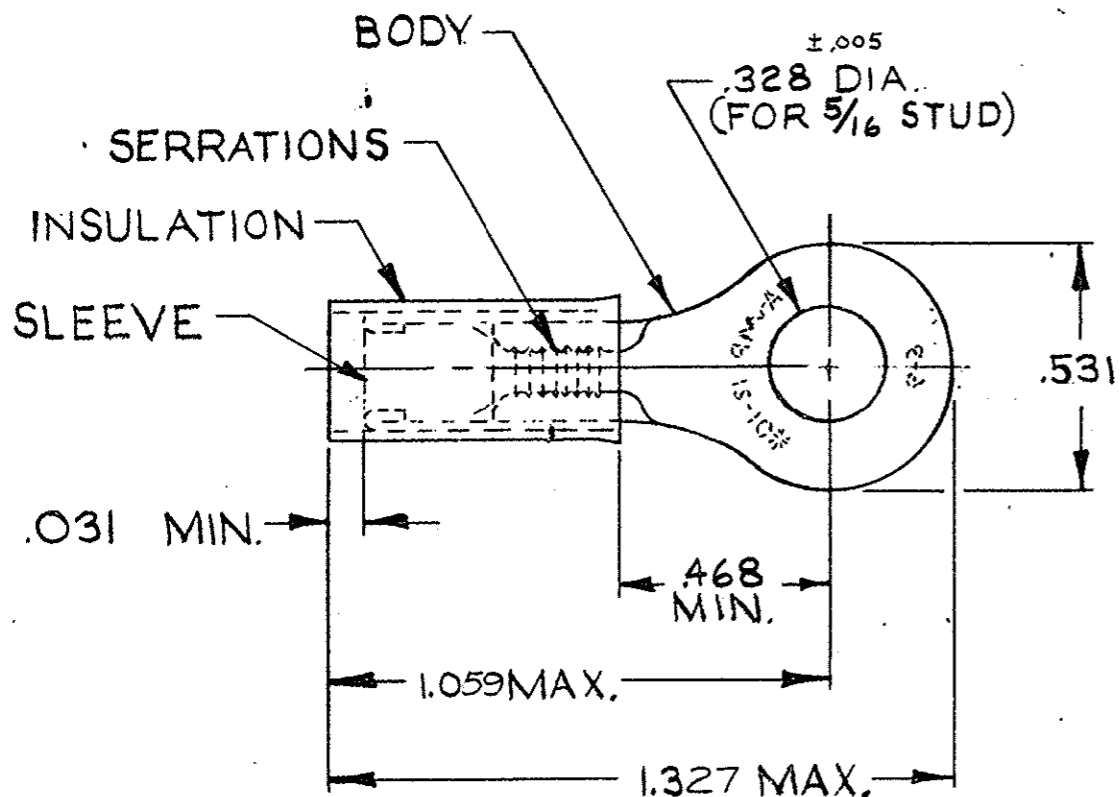

© 1967 BY AMP INCORPORATED. ALL RIGHTS RESERVED. AMP PRODUCTS COVERED BY PATENTS AND/OR PATENTS PENDING.



FOR .102 TO .214 WIRE INSULATION DIA.  
TONGUE MATERIAL THK. = .040 ±.002

OBSOLETE

REVISIONS					
ZONE	LTR	DESCRIPTION		DATE	APPROVED
	B	REDRAWN & REV	P-6077	SK 7-20-69	FCY
	C	REVISED	PC-5579	WM 10-8-70	AME
	D	REVISED	PC-5578	H.B. 7-6-71	FCY
	E	REVISED	PC-5578	TC 2-23-77	L.D
	F	INACTIVATED -1	P-9257	DBH 2-1-82	DJM
	G	OBS. -1 REV G2582		BT 10-7-87	gjm
	H	REV/ DG10-0099-98		ME 2-4-99	su
	H1	REV PER ECR 05-013140		10/20/05	JR/TM

1	50847 ON TAPE	<del>50847-1</del>	BODY: COPPER (ASTM B152) NICKEL PLATE (QQ-N-290) .0003 AVG. EXT. THK.
1	WIRE TERMINAL	50847	SLEEVE: COPPER (ASTM B152) NICKEL PL (QQ-N-290).00003 AVG. EXT. THK. INSULATION: TEFLON (ASTM D3295) COLOR: BLACK
QTY	DESCRIPTION	PART NO.	MATERIAL & FINISH
UNLESS OTHERWISE SPECIFIED DIMENSIONS ARE IN INCHES TOLERANCES ON: DECIMALS ±.008 ANGLES ± 5°		CONTRACT NO. — 11 —	 AMP INCORPORATED HARRISBURG, PENNSYLVANIA
MATERIAL  SEE TABLE		DR. <i>Steve Fauts</i> 7-29-69 CHK. <i>P.C. Youngblood</i> 7-30-69 APPD. <i>L. W. Abel</i> 8-6-69 REL. <i>J.M. Eneninger</i> 8-6-69	
		DSGN APPD	SIZE B
		OTHER APPD	CODE IDENT NO. 00779
			NUMBER 50847
			SCALE NTS
			SHEET 10F1