

THIS DRAWING IS UNPUBLISHED. RELEASED FOR PUBLICATION, 19
 © COPYRIGHT 19 BY AMP INCORPORATED. ALL INTERNATIONAL RIGHTS RESERVED.

LOC	DIST	P	F	ZONE	LTR	DESCRIPTION	DATE	APPD
AF	50				J	ADDED -4 PER 0L10-0207-97	5/23/97	JR/JG

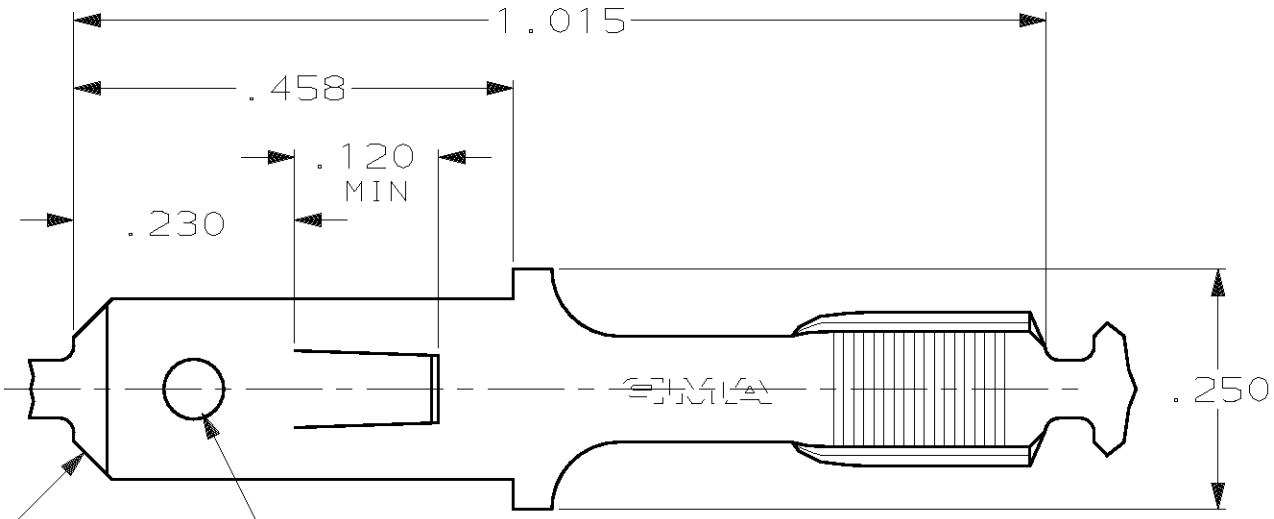

$\frac{.065}{.059}$ DIA HOLE

FITS .187 SERIES FASTON RECEPTACLE

- 1 CONTINUOUS STRIP ON REELS
- 2 REVERSE REELING OF 62447-1
- 3 VARNISH RESIST

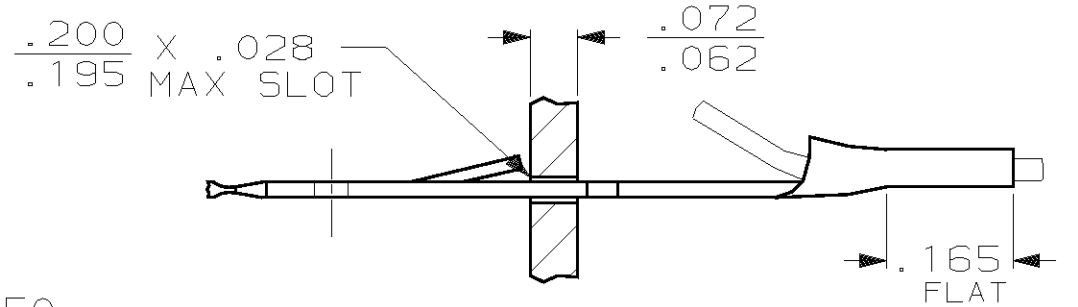

INSTALLED VIEW PIGTAIL CRIMP

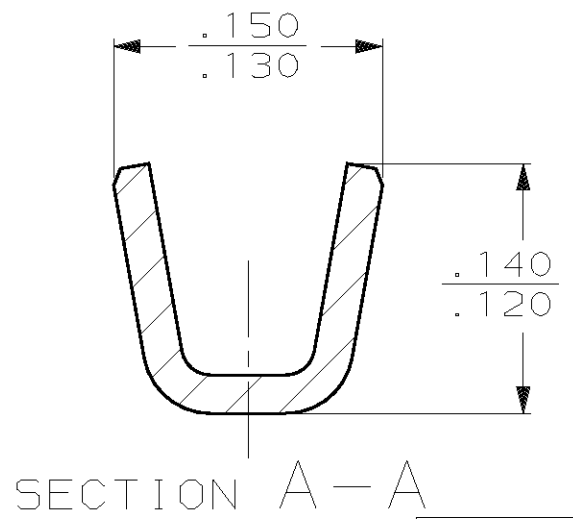
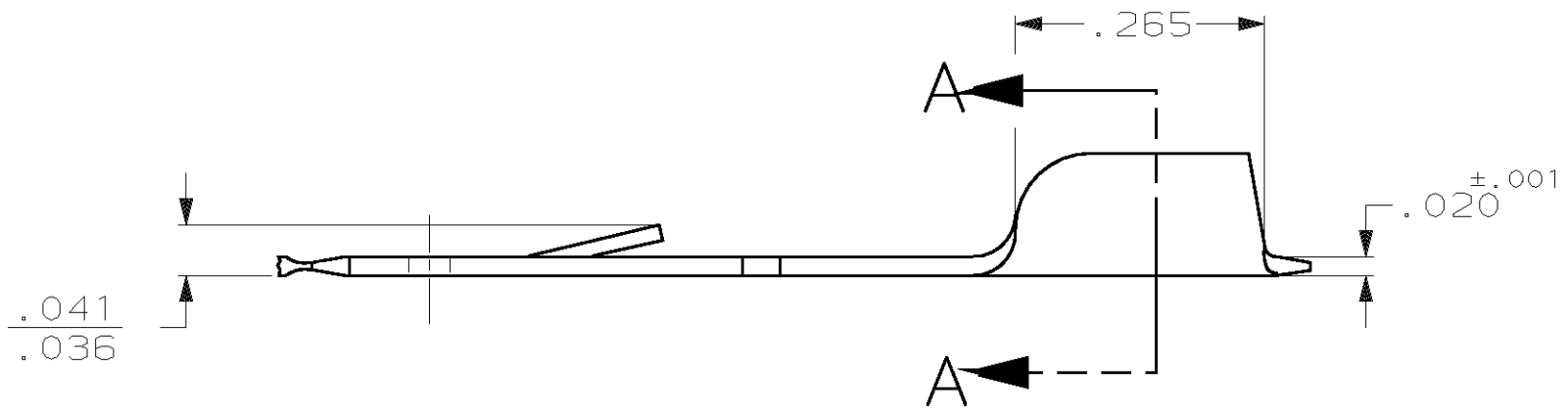

SECTION A-A

OBSOLETE	2 62447-4	3
	62447-3	3
#22-16 MAGNET WIRE 600 - 3000 CMA	2 62447-2	3
	62447-1	
WIRE SIZE	PART NO	

DO NOT SCALE PRINT. UNLESS SPECIFIED DIMENSIONS ARE IN INCHES. TOLERANCES ON: 2 PLC DEC ± - 3 PLC DEC ± .015 ANGLES ± -	DR 2/19/92 JR RUTH	AMP AMP Incorporated Harrisburg, PA 17105-3608		
	CHK 2/19/92 MS FEHER			
	MATERIAL H02 BRASS	APPD 2/19/92 J GILLESPIE	NAME TAB, AMPLIVAR, FASTIN-FASTON, .187 SERIES	
	FINISH TIN .000080 MIN	APPD 2/19/92 D REINER	SIZE B	CAGE CODE 00779
	PRODUCT SPEC -	SCALE 5:1	SHEET 1 OF 1	
	APPLICATION SPEC -			
	WEIGHT -			