

CATALOG NUMBER 47093

**CUSTOMER COPY
FOR REFERENCE ONLY**

USED ON

STA. NO.	ALT.
1	
2	
3	
4	
5	
36	D-1
7	
8	
9	
10	
11	
12	
13	
14	
15	
16	
17	
18	
19	
20	

302600
HEAD ASSEMBLY

300432
PIN
(2 REQ'D)
300386
RETAINING RING
(4 REQ'D)

300387
RETAINING RING
(2 REQ'D)

300449
PIN

39366
COLLAR

39364
SPRING

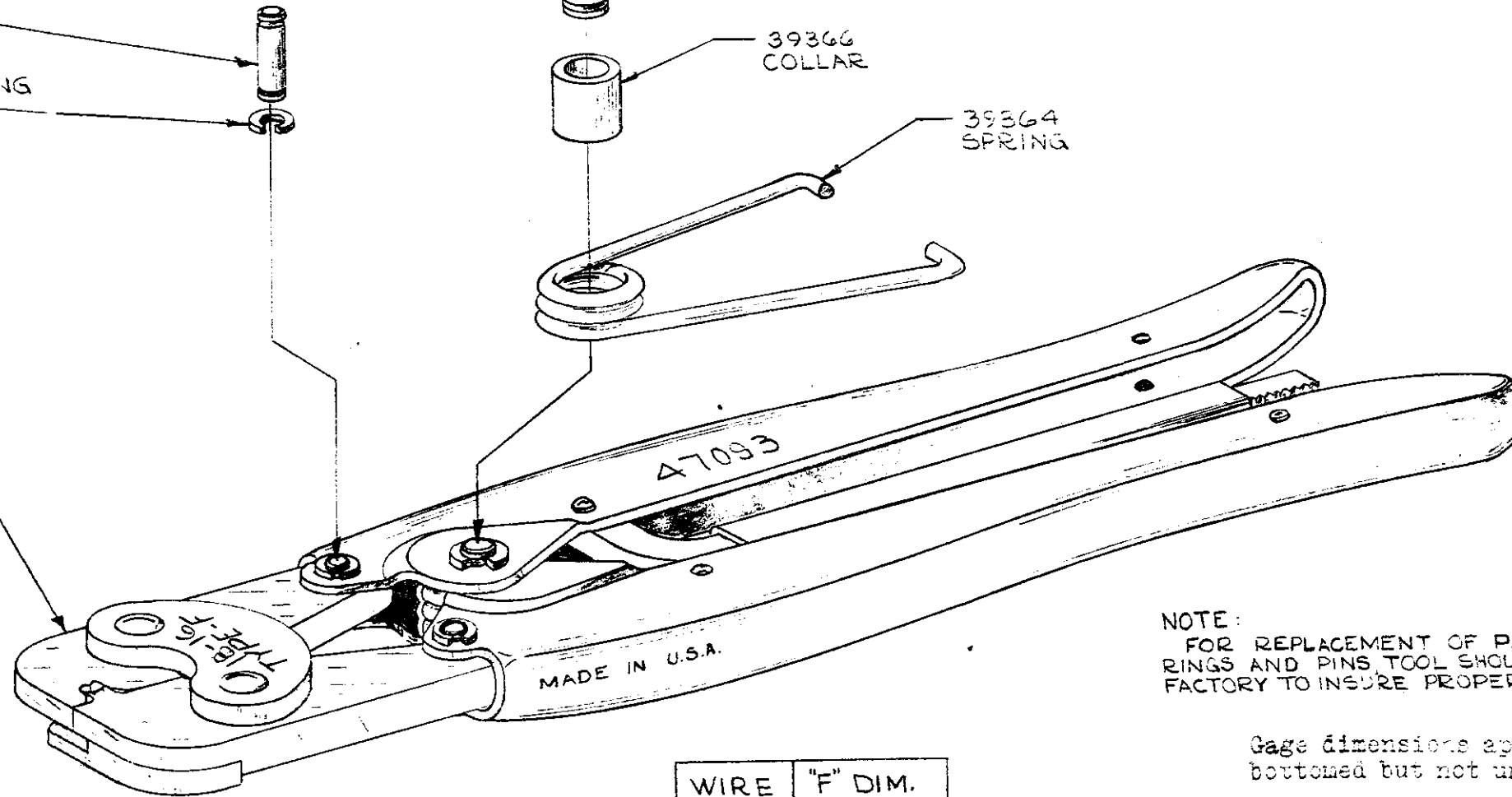

NOTE:
FOR REPLACEMENT OF PARTS OTHER THAN SNAP RINGS AND PINS TOOL SHOULD BE RETURNED TO OUR FACTORY TO INSURE PROPER CERTI-CRIMP ADJUSTMENT.

Gage dimensions apply when tool is bottomed but not under pressure.

WIRE SIZE	"F" DIM.	
	GO	NOGO
18-16	.058	.064

COPYRIGHT IN U.S.A. 1954 BY AMP-CRIMP PRODUCTS, INC.
COPYRIGHT 1954 BY THE COPYRIGHT UNION. ALL RIGHTS RESERVED UNDER INTERNATIONAL COPYRIGHT UNION (1954)

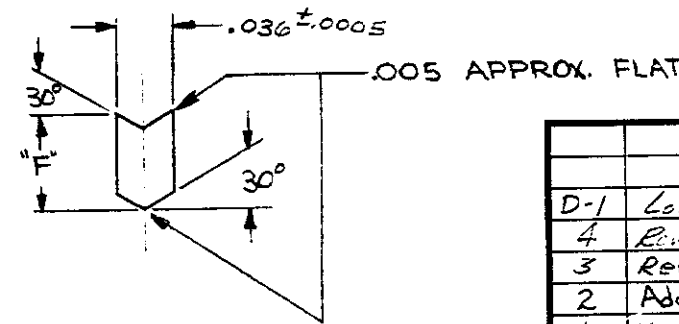
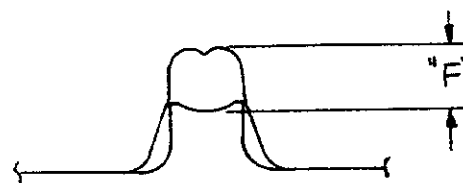

PROPOSED DESIGN
OF PLUG GAGE

AMP AMP INCORPORATED
HARRISBURG, PENNA.

DOUBLE ACTION HAND TOOL
ASSEMBLY

NO.	ALTERATION	DATE	BY	N.D.C.	CLASS
D-1	Loc M was R	9/1/54	TR		
4	Revised	7/8/54	TR	YES	
3	Revised	3/11/53	TR	NO	
2	Added Plug Gage Dims.	10-24-51	TR	E.J.F.	
1	Changed AS PER. PROD. DRAWING	6/2/55	TR	L.H.B.	
	RELEASED	11-18-54	TR	E.J.F.	

TYPE "F"-AN-CODED
SIZE 18-16
TOLERANCES- ALL DIMENSIONS ±N . EXCEPT AS NOTED.

MATERIAL:-

HEAT TREATMENT:-

FINISH:-

DR. P.J. FINLEY 11-18-54 TR. SCALE: CATALOG NUMBER 47093
 CK E.J. FINK 11/19/54 APP. R. WITMYER 11/19/54