

Sales Outline Drawing

Specifications:	cUL Recognized to IEC60601-1-8 - Artificial Perfusion MELODY		
Sound Level Category:	Loud	Loud	Loud
Mode of Operation:	Low Priority Alarm 2 beeps repeating every 30 sec	Medium Priority Alarm 3 beeps repeating every 7.5 sec	High Priority Alarm 10 beeps repeating every 2.5 sec
Loudness @ 10cm:	85 to 95 dB(A) Typ.	85 to 95 dB(A) Typ.	85 to 95 dB(A) Typ.
Frequency:	150 to 4000 Hz		
Connection:	Connect "+" to "+" & "- " to "- " of Power Supply	Connect "+" to "+" & "- " & Medium to "- " of Power Supply	Connect "+" to "+" & "- " & High to "- " of Power Supply
Voltage Rating:	5 ± 0.5 VDC		
Average Current Draw:	<45mA Typ.	<70mA Typ.	<150mA Typ.
Ipk Current*:	400mA		
Housing Material:	Valox (UL94V-0), Octagonal, Black		
Storage Temperature:	-30° to +60° C		
Operating Temperature:	-30° to +55° C		
Weight (Typical):	6.0g		
Options:	Please contact factory.		

Dimensions: Inches [mm] **cUL Recognized** **ROHS Compliant**

PATENT NUMBER: 7880593

Before Code Date: 1546 Not cUL Recognized

After Code Date: 1547 cUL Recognized

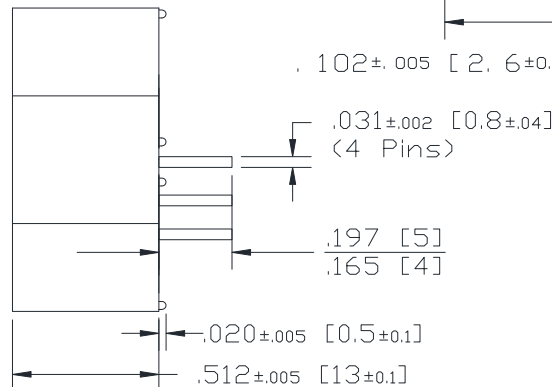
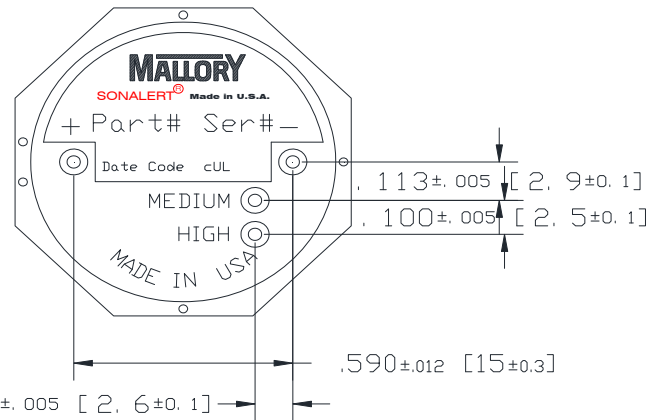
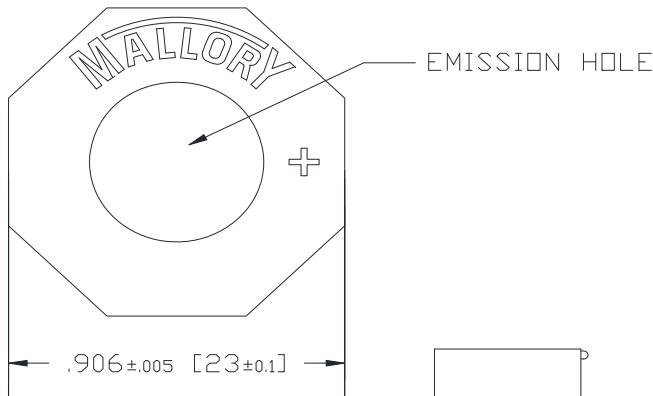

NOTE A:
TERMINALS - .031" DIA. NICKEL/TIN COATED BRASS.

NOTE B:
MOUNTING- INSERT INTO PRINTED CIRCUIT BOARD AND HAND OR MACHINE SOLDER.
UNITS ARE SUITABLE FOR WAVE SOLDERING. BOARDS ARE NOT SUITABLE FOR WASH.
RECOMMENDED MAXIMUM TEMPERATURE AND TIME DURATION FOR WAVE SOLDERING IS
+270°C AND 3 SECONDS RESPECTIVELY.