

THIS DRAWING IS UNPUBLISHED. RELEASED FOR PUBLICATION
 © COPYRIGHT - By - ALL RIGHTS RESERVED.

| LOC | DIST | REVISIONS | | | |
|-----|------|-------------|-----------------------|---------|-------|
| P | LTR | DESCRIPTION | DATE | DWN | APVD |
| AF | 50 | C | REV PER ECR 11-001883 | 06APR11 | JR PD |

- 1 CONTINUOUS STRIP ON REELS
- 2 WIRE SIZE IS #18-#14 AWG
- 3 INSULATION RANGE IS .120-.170 DIA
- 4 MATING TAB THK IS .032±.001

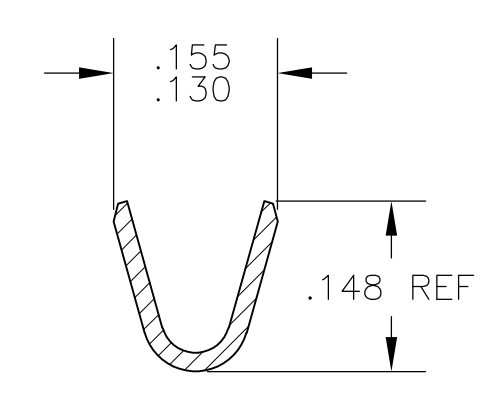
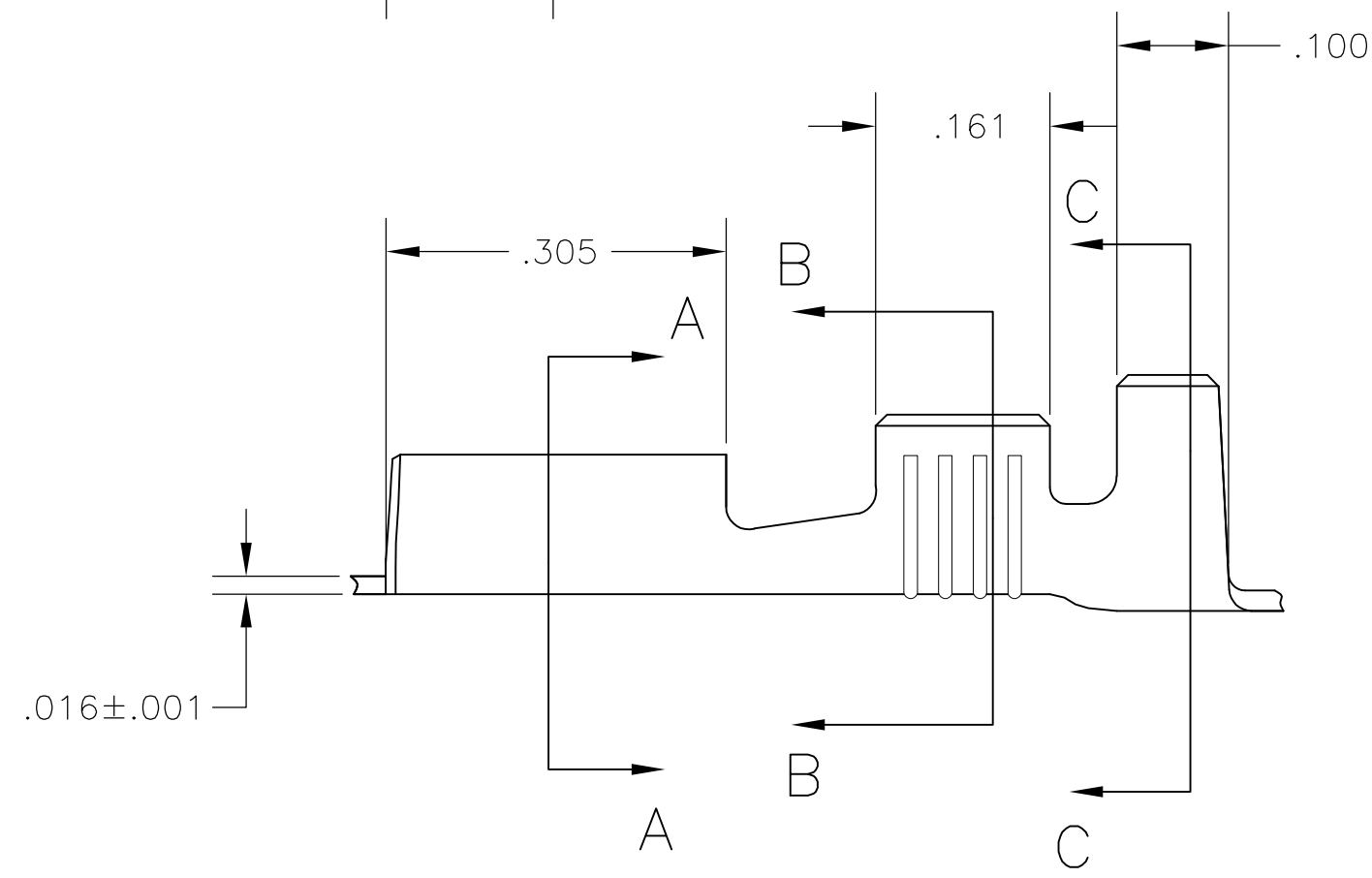
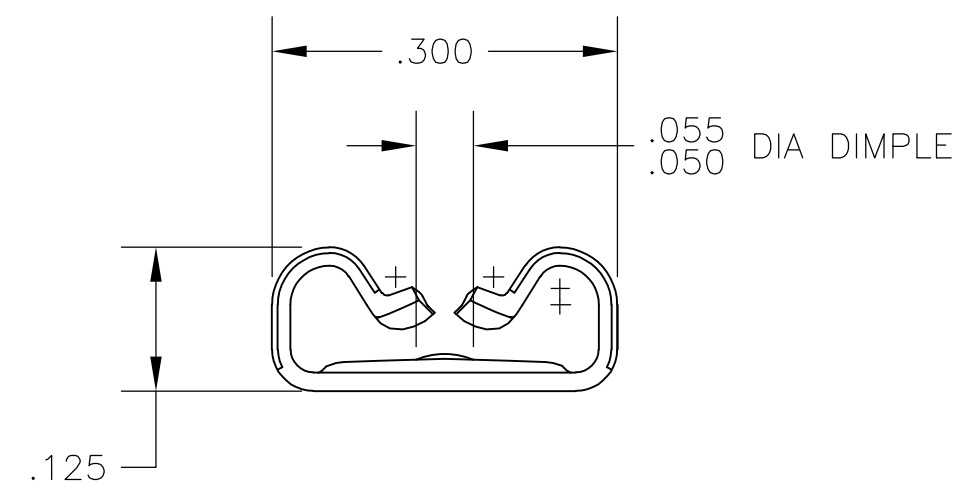
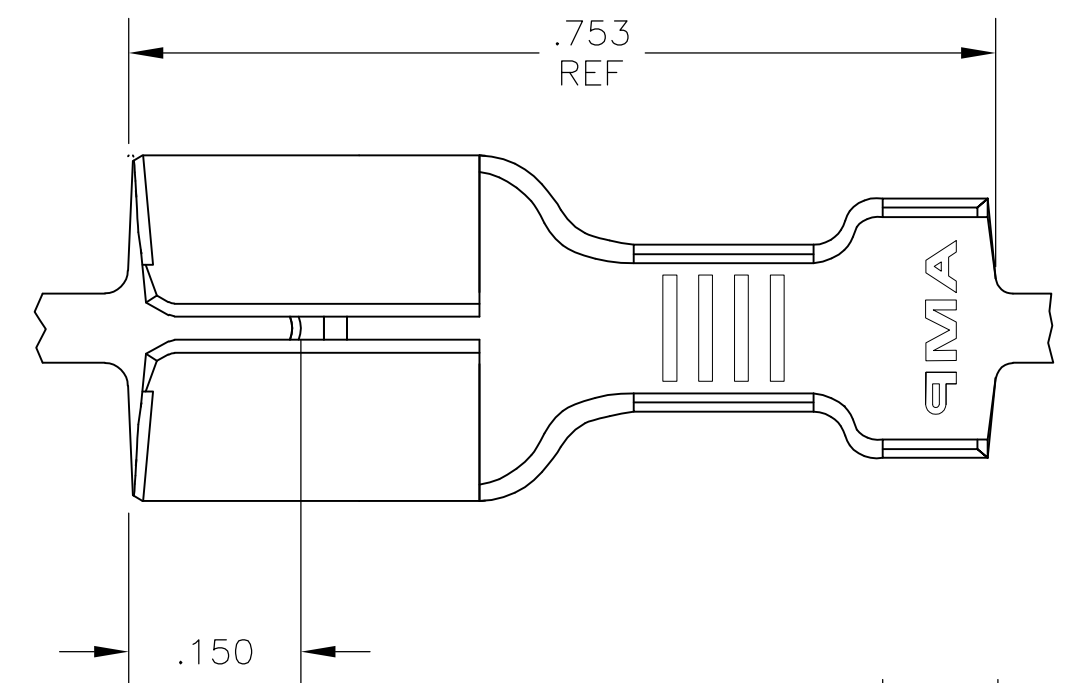

SECTION B-B

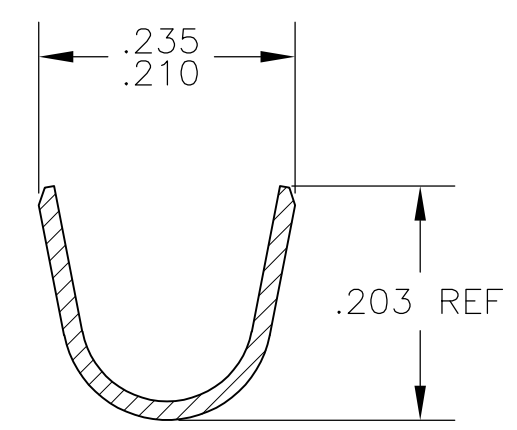

SECTION C-C

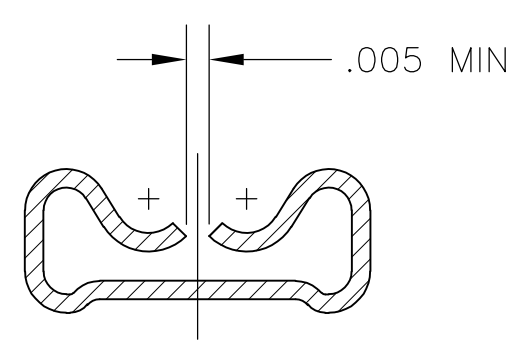

SECTION A-A

1742198-1
PART NO

| | | | | | | | | | | | | | | | | | | | | | | |
|--|------------------------------|------------------------------|---|--------------------|-------|---|---|-------|---|---|-------|---|------|-------|---|---|--------|---|----|-------------------|------------|--------------------|
| THIS DRAWING IS A CONTROLLED DOCUMENT. | | DWN jr ruth 22OCT04 | | | | | | | | | | | | | | | | | | | | |
| DIMENSIONS: INCHES | | CHK B FLAIG 22OCT04 | | | | | | | | | | | | | | | | | | | | |
| TOLERANCES UNLESS OTHERWISE SPECIFIED: | | APVD ED HOWARD 22OCT04 | NAME RECEPTACLE, FASTON, STEEL, .250 SERIES | | | | | | | | | | | | | | | | | | | |
| <table border="0"> <tr><td>0 PLC</td><td>±</td><td>-</td></tr> <tr><td>1 PLC</td><td>±</td><td>-</td></tr> <tr><td>2 PLC</td><td>±</td><td>-</td></tr> <tr><td>3 PLC</td><td>±</td><td>.010</td></tr> <tr><td>4 PLC</td><td>±</td><td>-</td></tr> <tr><td>ANGLES</td><td>±</td><td>5°</td></tr> </table> | | 0 PLC | ± | - | 1 PLC | ± | - | 2 PLC | ± | - | 3 PLC | ± | .010 | 4 PLC | ± | - | ANGLES | ± | 5° | PRODUCT SPEC - | SIZE A2 | CAGE CODE 00779 |
| 0 PLC | ± | - | | | | | | | | | | | | | | | | | | | | |
| 1 PLC | ± | - | | | | | | | | | | | | | | | | | | | | |
| 2 PLC | ± | - | | | | | | | | | | | | | | | | | | | | |
| 3 PLC | ± | .010 | | | | | | | | | | | | | | | | | | | | |
| 4 PLC | ± | - | | | | | | | | | | | | | | | | | | | | |
| ANGLES | ± | 5° | | | | | | | | | | | | | | | | | | | | |
| MATERIAL H02 STEEL | FINISH .000150 MIN NICKEL | APPLICATION SPEC - | DRAWING NO C=1742198 | RESTRICTED TO - | | | | | | | | | | | | | | | | | | |
| CUSTOMER DRAWING | | | SCALE 6:1 | SHEET 1 of 1 | | | | | | | | | | | | | | | | | | |
| | | | REV C | | | | | | | | | | | | | | | | | | | |

1742198