

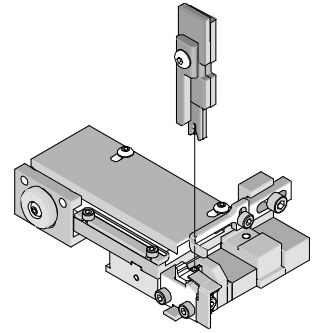

# T2 Terminator Tooling Specification Sheet Order No. 63910-6500



## FEATURES

- It is ideally suited for mid-volume bench operations
- This terminator can be installed in the TM42 and the TM40 press or Base Unit adapter for 3BF press
- Quick punch removal with the push of a button for fast and easy tooling change
- Track adjustment capabilities in the T2 Terminators for improved control of the bell mouth size and cutoff tab length
- T2 Terminator has standardized tooling with the Molex FineAdjust Applicator which will reduce your inventory requirements

## SCOPE

Products: Picoflex® Discrete Wire Crimp Terminal, 24-28 AWG.

Terminal Series No.	Terminal Order No.	Wire Size		Insulation Diameter		Strip Length	
		AWG	mm <sup>2</sup>	mm	In.	mm	In.
91821	91821-0001	24-28	0.20-0.09	0.90-1.50	.035-.059	2.00-2.50	.079-.098
	91821-0003						

## DEFINITION OF TERMS

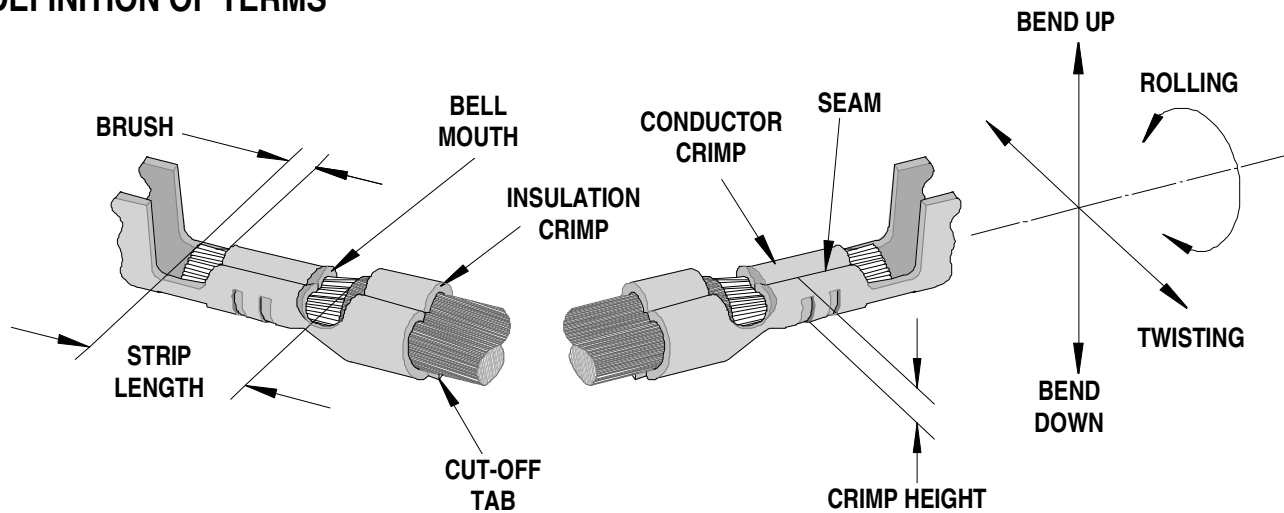

The above terminal drawing is a generic terminal representation. It is not an image of a terminal listed in the scope.

## INSULATION CRIMP FORM

This crimp terminal is designed for miniaturization; therefore each dimension of insulation crimp portion appears small as compared to the terminal material thickness. In order to avoid insulation piercing the crimp forms by the insulation barrel, coining is provided inside of the insulation barrel. For this reason, various crimp forms will occur at the tip of the insulation crimp barrel shown in the figure below.

These crimp forms maybe changed completely by a small change in the wire, insulation punch or terminal.

These crimp forms are satisfactory for original function of the insulation crimp portion and it is confirmed that all of these forms below are acceptable insulation crimps.

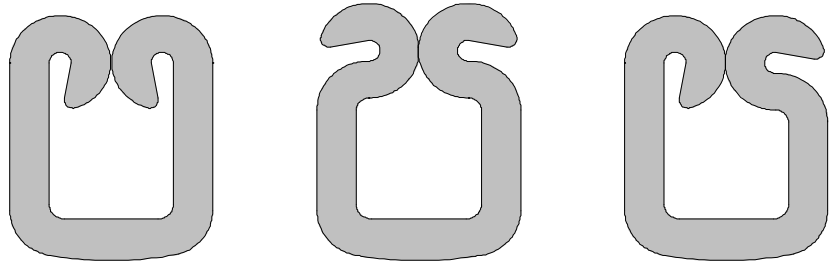

## CRIMP SPECIFICATION

Terminal Series No.	Bell mouth		Cut-off Tab Maximum				Conductor Brush	
			Front (Contact)		Rear (Contact)			
	mm	In.	mm	In.	mm	In.	mm	In.
91821	0.20-0.40	.008-.016	0.10	.004	0.15	.006	0.20-0.70	.008-.028

Terminal Series No.	Bend up	Bend down	Twist	Roll	Punch Width mm (Ref)				Seam Seam shall not be open and no wire allowed out of the crimping area
					Conductor		Insulation		
	Degree	Degree	mm	In	mm	In			
91821	3	3	3	8	1.00	.039	1.80	.071	

After crimping, the conductor profile should measure the following.

Terminal Series No.	Wire Size		Conductor Crimp Height		Insulation Crimp Height Maximum		Pull Force Minimum	
	AWG	mm <sup>2</sup>	mm	In.	mm	In.	N	Lb.
	91821	24	0.20	0.67-0.72	.026-.028	1.65	.065	30.0
26		0.12	0.64-0.69	.025-.027	1.65	.065	20.0	4.5
28		0.08	0.60-0.65	.024-.026	1.65	.065	10.0	2.3

Pull Force should be measured with no influence from the insulation crimp.  
The above specifications are guidelines to an optimum crimp.

**PARTS LIST**

<b>T2 Terminator 63910-6500</b>				
<b>Item</b>	<b>Order No</b>	<b>Engineering No.</b>	<b>Description</b>	<b>Quantity</b>
<b>Perishable Tooling</b>				
	63910-6570	63910-6570	Tool Kit (All "Y" Items)	REF
1	63444-1005	63444-1005	Conductor Punch	1 Y
2	63445-1010	63445-1010	Conductor Anvil	1 Y
3	63446-1810	63446-1810	Insulation Punch	1 Y
4	63445-1820	63445-1820	Insulation Anvil	1 Y
5	63443-0003	63443-0003	Cut-Off Plunger	2 Y
6	63443-0012	63443-0012	Front Plunger Retainer	1 Y
7	63443-1403	63443-1403	Cut-off Die Blade	1 Y
8	63443-1002	63443-1002	Rear Plunger Retainer	1 Y
<b>Other Components (REF 106550)</b>				
9	11-18-4083	60707-8	Feed Guide	1
10	11-24-1067	4996-4	Cut-Off Plunger Spring	2
11	11-40-4039	8302-5	Plunger Striker	1
12	63443-0009	63443-0009	Scrape Chute	1
13	63443-0024	63443-0024	Key	1
14	63443-0085	63443-0085	Wire Stop L-Bracket	1
15	63443-0090	63443-0090	Wire Stop	1
16	63443-1740	63443-1740	21.00mm Height Spacer	1
17	63443-2133	63443-2133	Spacer	1
18	63443-2203	63443-2203	3.00mm Coarse Spacer	1
19	63443-2312	63443-2312	3.60mm Fine Spacer	1
20	63443-6003	63443-6003	Rear Cover	1
21	63800-8506	63800-8506	Rear Striker	1
<b>Frame</b>				
22	63800-8500	63800-8500	T2 Terminator	1
<b>Hardware</b>				
23	N/A	N/A	M3 by 6 Long SHCS	2**
24	N/A	N/A	M3 by 6 Long FHCS	1**
25	N/A	N/A	M4 by 6 Long SHCS	2**
26	N/A	N/A	M4 by 12 Long BHCS	2**
27	N/A	N/A	M4 by 14 Long SHCS	2**
28	N/A	N/A	M4 by 50 Long SHCS	2**
29	N/A	N/A	M5 by 10 Long SHCS	1**
30	N/A	N/A	M5 by 12 Long SHCS	1**
31	N/A	N/A	#10-32 by 3/8" Long BHCS	1**
** Available from an industrial supply company such as MSC (1-800-645-7270).				

### Assembly Drawing

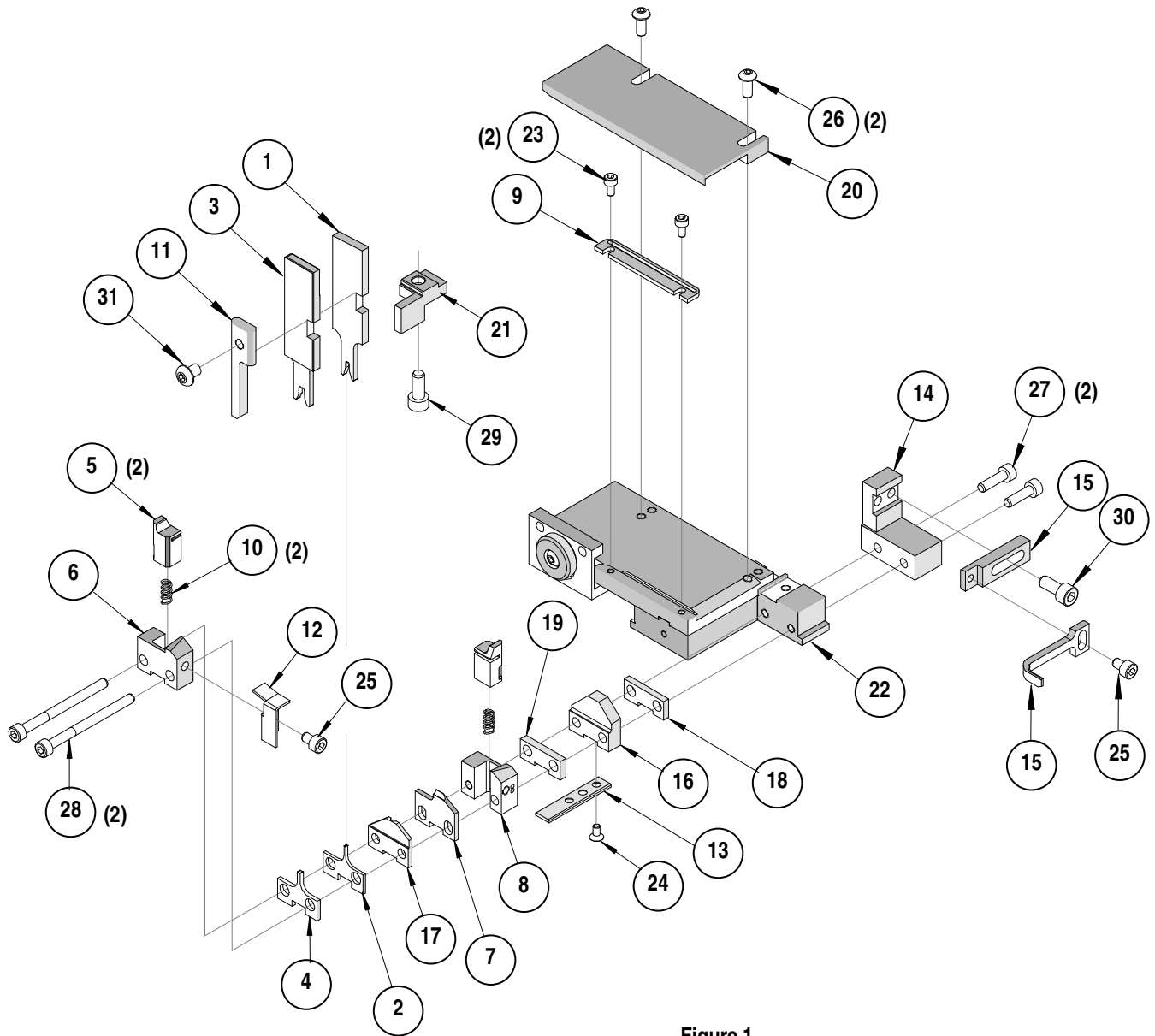

Figure 1

## NOTES

Depending on the press vintage a feed finger assembly is supplied with the T2 Terminator.

1. To remove the existing feed finger assembly loosens the M4 x 10 mm set screw in the feed lever.
2. Select T2 Feed finger assembly from Terminator box.
3. Insert a screwdriver into the slot behind the feed lever and force the feed arm spring to the right.
4. Slide the T2 feed finger shaft for TM42 (11-40-5307) or (11-40-0123) for TM40 /Base Unit into the feed lever and to the left of the feed arm spring.
5. Release the feed arm spring.
6. Position feed finger for selected product. (Refer to Figure 5.1 in the T2 Manual).

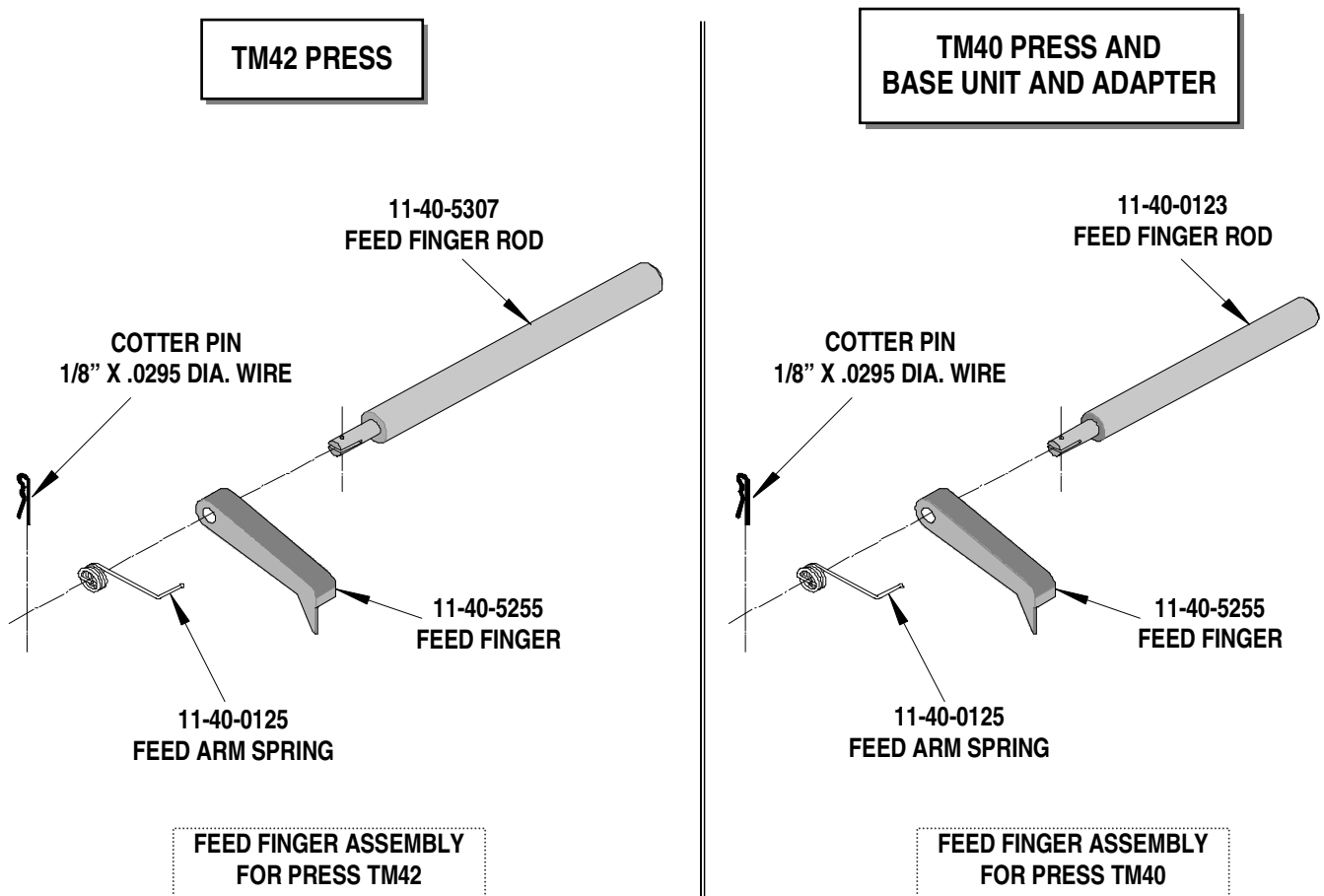

Figure 2

## NOTES

1. Molex recommends an extra perishable tooling kit be maintained at your facility.
2. Verify tooling alignment by manually cycling the press before crimping under power. Check that all screws are tight.
3. Slugs, Terminals, Dirt and Oil should be kept clear of work area.
4. This Terminator should be only used in a Molex TM42, TM40, or 3BF Press with a Base Unit adaptor.
5. Wear safety glasses at all times.
6. For recommended maintenance refer to the TM40, TM42 Manual.

**CAUTION:** To prevent injury never operate this Terminator without the guards supplied with the press or in place. Reference the TM42 press manufacturer's instruction manual.

**CAUTION:** Molex crimp specifications are valid only when used with Molex terminals, applicators and tooling.

**Americas Headquarters**  
Lisle, Illinois 60532 U.S.A.  
1-800-78MOLEX  
amerinfo@molex.com

**Far East North Headquarters**  
Yamato, Kanagawa, Japan  
81-462-65-2324  
feninfo@molex.com

**Far East South Headquarters**  
Jurong, Singapore  
65-6-268-6868  
fesinfo@molex.com

**European Headquarters**  
Munich, Germany  
49-89-413092-0  
eurinfo@molex.com

**Corporate Headquarters**  
2222 Wellington Ct.  
Lisle, IL 60532 U.S.A.  
630-969-4550  
Fax: 630-969-1352

Visit our Web site at <http://www.molex.com>