

PART NUMBER	REV	FIRST USED
567196-1	B	565435-5
567196-2	B	354500-1

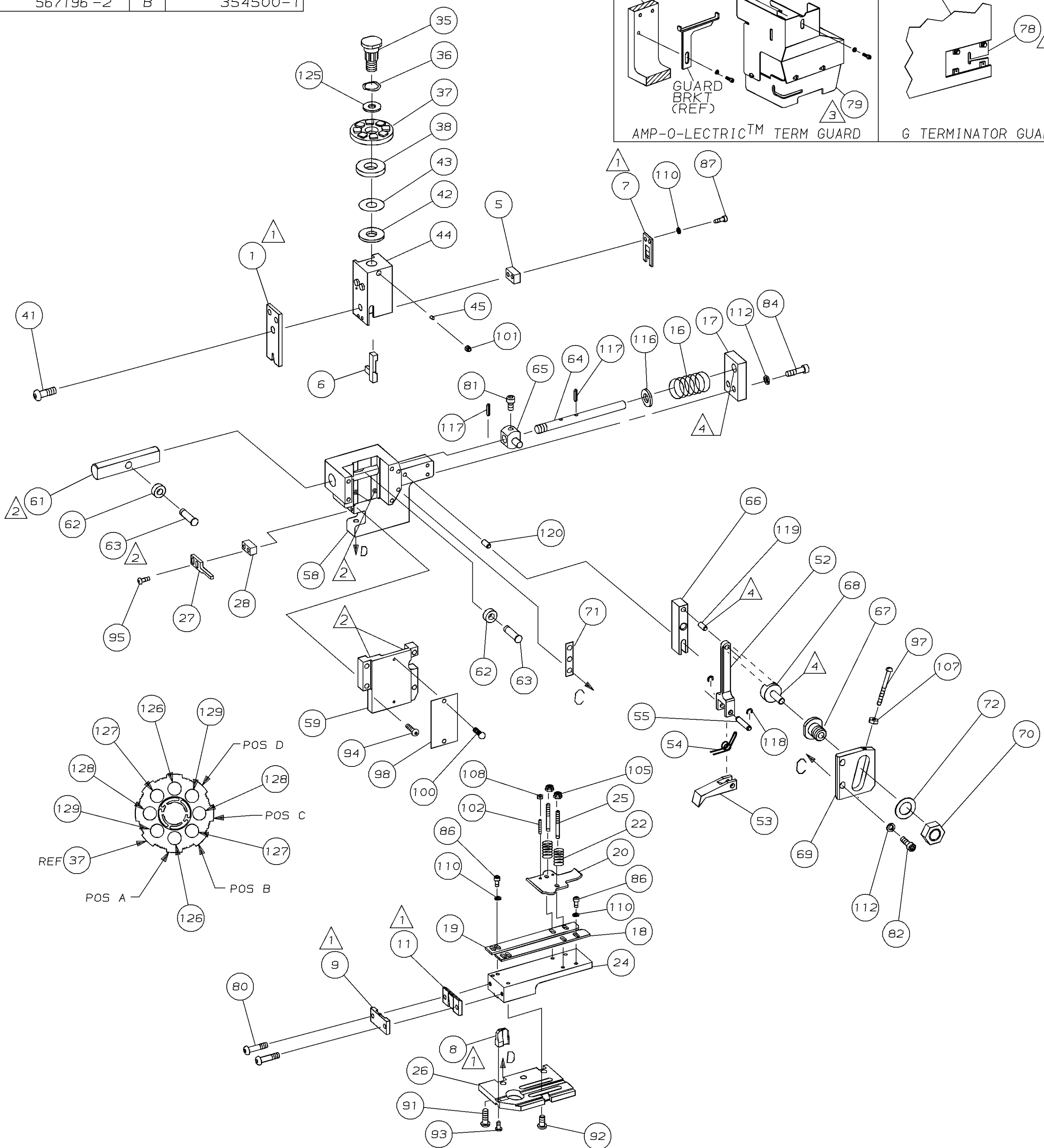
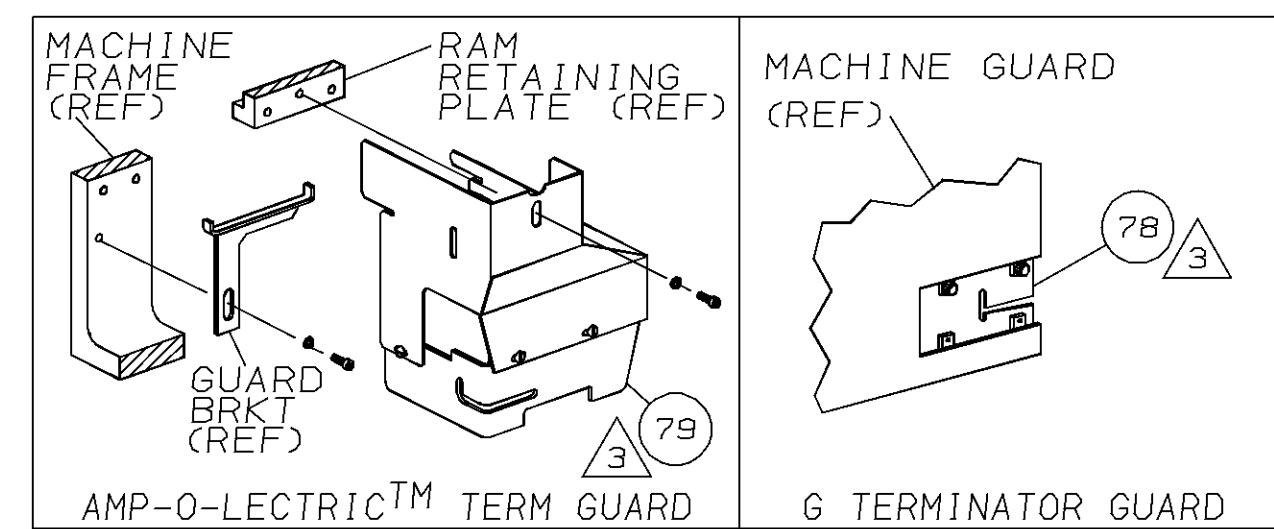

TERMINAL NAME: AMPLIVAR™ RING TONGUE				
63147				
PAD LTR		CRIMP HEIGHT		WIRE SIZE
A	.076 ±.002	[1.93 ±0.05mm]		13 1/2 OR 14
B	.072 ±.002	[1.83 ±0.05mm]		15
C	.068 ±.002	[1.73 ±0.05mm]		16
D	.064 ±.002	[1.63 ±0.05mm]		17
CRIMP	SIZE	TYPE	RANGE	
WIRE	.110	[2.79mm]	F	17-13 1/2
INSUL	-	-	-	-

QTY	REV	U/M	DWG SIZE	PART NO	DESCRIPTION	ITEM NO
2	2	-	C	9-354778-3	PIN, WIRE DISC (.2960)D	129
2	2	-	C	8-354778-5	PIN, WIRE DISC (.2920)C	128
2	2	-	C	7-354778-7	PIN, WIRE DISC (.2880)B	127
2	2	-	C	6-354778-9	PIN, WIRE DISC (.2840)A	126
1	1	-	A	986950-1	WASHER, FLAT PRECISION	125
1	1	-	A	217238-1	GENERAL INSTRUCTION PACKAGE	124
1	1	-	-	4088039	EF APPL INST 408-8039	123
REF	REF	-	A	1-21030-7	PIN, DOWEL (Ø.187x1.50) HSG	120
REF	REF	-	A	1-21030-1	PIN, DOWEL (Ø.187x.50) LEVER	119
REF	REF	-	A	21045-3	RING, RET "C" (Ø.187) FD PIN	118
REF	REF	-	A	5-21028-1	PIN, STD SPRING (Ø.12) FD ADJ ROD	117
REF	REF	-	A	21899-4	WASHER, FLAT (Ø5/16) SCR ADJ	116
REF	REF	-	A	21024-5	WASHER, LOCK (NO.10) FD ROD GDE	115
6	6	-	A	21024-4	WASHER, LOCK (NO.8) SHEAR BL	110
2	2	-	A	21018-4	NUT, HEX (4-40) DRAG	108
REF	REF	-	A	21018-5	NUT, HEX (6-32) FD ADJ PL	107
2	2	-	A	21022-2	NUT, HEX SL (8-32) DRAG STUD	105
2	2	-	A	2-21006-6	SCR, SKT SET (4-40x.62) DRAG	102
1	1	-	A	21009-2	SCR, SKT SET (1/4-20x.25 ) RAM	101
2	2	-	A	21017-2	SCR, DRIVE (#2x.19) ID PLATE	100
1	1	-	A	1-21002-7	SCR, BHC (6-32x.38) CAM	99
1	1	-	B	461264-1	PLATE, IDENTIFICATION	98
REF	REF	-	A	6-23715-5	SCR, PAN HD (6-32x1.50) FEED ADJ	97
2	2	-	A	2-21002-2	SCR, BHC (8-32x.50) STRIPPER	95
REF	REF	-	A	2-21002-9	SCR, BHC (10-32x.75) HSG CAP	94
1	1	-	A	22733-8	SCR, BHC (8-32x.38 LW) ANVIL	93
4	4	-	A	3-21002-3	SCR, BHC (1/4-20x.50) ST 6D PL	92
REF	REF	-	A	2-22733-8	SCR, BHC (1/4-20x.62) BASE PL	91
2	2	-	A	2-21000-8	SCR, SHC (8-32x.62) SLUG BLADE	87
4	4	-	A	2-21000-6	SCR, SHC (8-32x.38) STRIP GUIDE	86
REF	REF	-	A	3-21000-7	SCR, SHC (10-32x.75) FEED ROD GDE	84
REF	REF	-	A	3-21000-6	SCR, SHC (10-32x.62) FEED ADJ PL	82
REF	REF	-	A	3-21000-4	SCR, SHC (10-32x.38) PIVOT BLOCK	81
2	2	-	A	3-21002-0	SCR, BHC (10-32x.88) SHEAR PL	80
-	REF	-	A	455745-1	GUARD, WINDOW	79
REF	-	-	A	679532-1	INSERT, GUARD	78
REF	REF	-	A	458109-1	WASHER, FLAT (SPECIAL)	72
REF	REF	-	A	690517-1	SPACER	71

QTY	REV	U/M	DWG SIZE	PART NO	DESCRIPTION	ITEM NO	
-1	REF	REF	-	A	22594-8	NUT, HEX	70
-2	REF	REF	-	B	240628-1	PLATE, ADJ	69
REF	REF	-	B	240626-1	SHAFT, PIVOT	68	
REF	REF	-	B	240633-1	BUSHING	67	
REF	REF	-	A	455680-1	LEVER, INTERMEDIATE	66	
REF	REF	-	B	240629-1	BLOCK, PIVOT	65	
REF	REF	-	A	240632-2	SCR, ADJ	64	
REF	REF	-	B	240659-3	PIN, CAM ROLLER	63	
REF	REF	-	B	240658-1	CAM, ROLLER	62	
REF	REF	-	B	454398-1	ROD, FEED	61	
REF	REF	-	C	454220-1	CAP, RAM	59	
REF	REF	-	D	453736-1	HOUSING	58	
REF	REF	-	B	240624-1	PIN, FEED FINGER	55	
REF	REF	-	B	691499-1	SPRING, FEED FINGER	54	
REF	REF	-	B	240635-1	FINGER, FEED	53	
REF	REF	-	B	240634-1	LEVER, TERMINAL	52	
-	1	-	B	690602-5	CAM, PRE FEED 1 1/8 ST	48	
1	-	-	B	690501-4	CAM, POST FEED 1 5/8 ST	47	
1	1	-	A	690191-1	PLUG, NYLON	45	
1	1	-	C	455674-1	RAM	44	
1	1	-	A	690125-1	WASHER, LAMINATED	43	
1	1	-	A	690124-1	WASHER, RAM	42	
1	1	-	A	7-21002-9	BOLT, CRIMPER (5/16-24x1.00)	41	
1	1	-	A	690223-2	SPACER, INSULATION DISC	38	
1	1	-	D	354777-1	WIRE DISC, PLASTIC	37	
1	1	-	A	22480-5	WASHER, SPRING	36	
1	1	-	B	690212-1	POST, RAM	35	
1	1	-	D	458980-1	APPLICATOR, BASIC (SUB ASSY)	32	
1	1	-	B	3-690451-7	SPACER, STRIPPER	28	
1	1	-	A	240639-1	STRIPPER	27	
REF	REF	-	C	455676-1	PLATE, BASE	26	
2	2	-	A	22354-8	DRAG, STUD	25	
1	1	-	B	455678-1	PLATE, STRIP GUIDE	24	
2	2	-	A	4-22281-1	SPRING, DRAG	22	
1	1	-	A	454177-1	DRAG, STOCK	20	
1	1	-	B	1-458030-1	GUIDE, STRIP (REAR)	19	
1	1	-	C	1-458031-1	GUIDE, STRIP (FRONT)	18	
REF	REF	-	A	454178-1	GUIDE, FEED ROD	17	
REF	REF	-	A	4-22284-9	SPRING, FEED RETURN	16	
1	1	-	B	240644-1	PLATE, REAR SHEAR	11	
1	1	-	B	690482-5	PLATE, FRONT SHEAR	9	
1	1	-	D	1-456537-4	ANVIL	8	
1	1	-	B	690474-5	BLADE, SLUG	7	
1	1	-	D	460801-6	HOLD DOWN, TERMINAL	6	
1	1	-	C	2-240641-0	SPACER, SLUG BLADE	5	
1	1	-	C	456422-6	CRIMPER, WIRE	1	

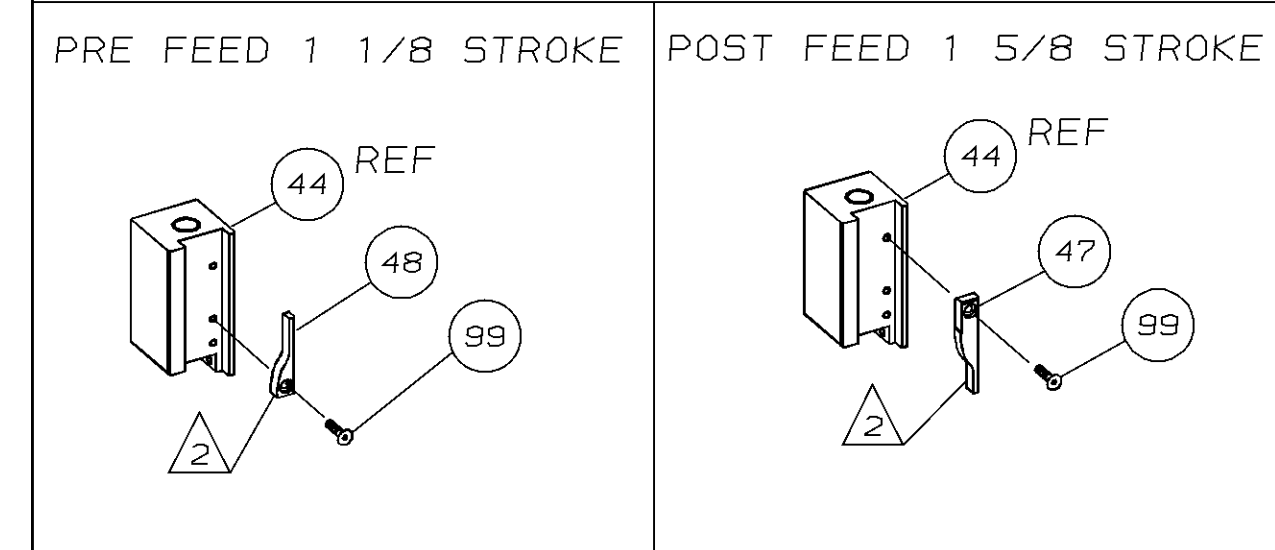

- ① RECOMMENDED SPARE PARTS.
- ② GREASE LIGHTLY.
- ③ GUARD MUST BE IN PLACE WHEN OPERATING APPLICATOR IN A BENCH MACHINE.
- ④ LUBRICATE DAILY USING NO. 20 MACHINE OIL.
- ⑤ ITEMS WITH QTY OF REF SPECIFIED (EXCEPT ITEMS 78 AND 79) ARE USED ON ITEM 32.
- ⑥ ITEM 78 USED WITH G TERMINATOR ONLY.

LOC A	K TERMINATOR BENCH MACHINE
DIST 66	LEADMAKER & G TERMINATOR BENCH MACHINE

QTY	REV	U/M	DWG SIZE	PART NO	DESCRIPTION	ITEM NO
-2	-1	U/M	DWG SIZE	PART NO	DESCRIPTION	ITEM NO