

ACCESSORIES

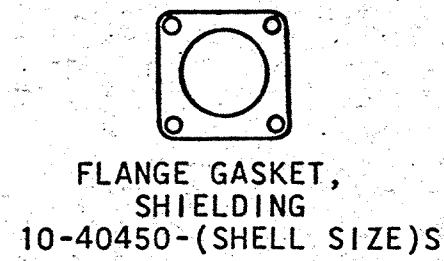
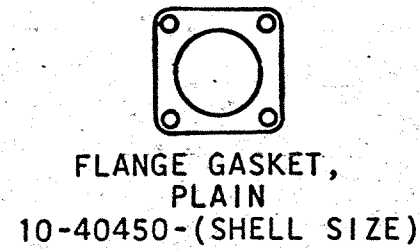

CONTACT DATA (WHERE APPLICABLE)

THERMOCOUPLE		COAXIAL	
MATERIAL	IDENTIFICATION	ARR	CABLE
CHROMEL	WHITE		
ALUMEL	GREEN		
IRON	BLACK		
CONSTANTAN	YELLOW		

INSERT ARRANGEMENTS CONTAINING THERMOCOUPLE OR COAXIAL CONTACTS MUST HAVE SUCH CONTACTS ASSEMBLED INTO THE INSERT IN PROPER LOCATIONS AS SPECIFIED BY APPLICABLE DRAWING L-11908-() THRU L-11948-().

35508-462

ZONE	LTR	DESCRIPTION	DATE	APPROVED
	A8	REDRAWN SAME SIZE; REVISED & STANDARDIZED (SEE NOTICE OF CHANGE) ECN: 55525-40	12-1-72 AMBRECHT	<i>Harmon</i>
	B	(MFG); ADD. 9-3895 (PROCESS SPEC); REV STAMPING NOTE ECN: 57216-2	12-22-75 <i>Harmon</i>	<i>Harmon</i>
	C	(MFG); REV STAMPING NOTE 14 ECN: 57738-1	5-19-76 BOWKER	<i>Shaver</i>
	D	(CL II) SEE CHANGE NOTICE ECN: 74790-5	12-14-83 Prescott	<i>Had</i>

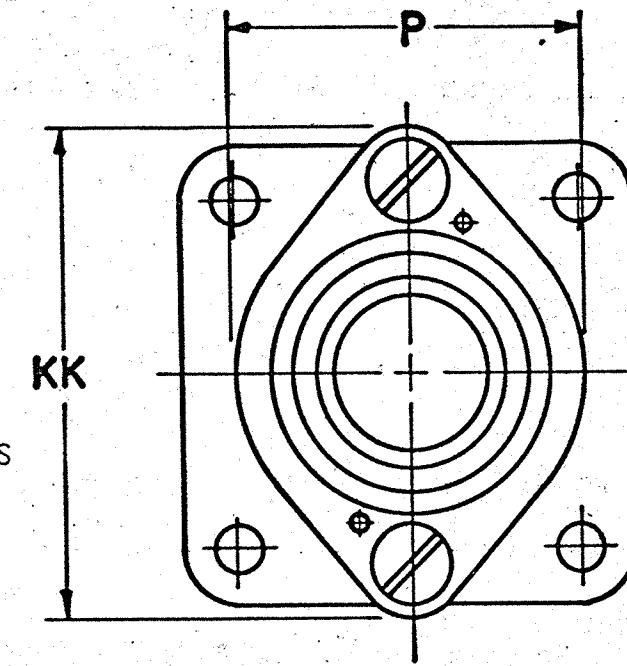
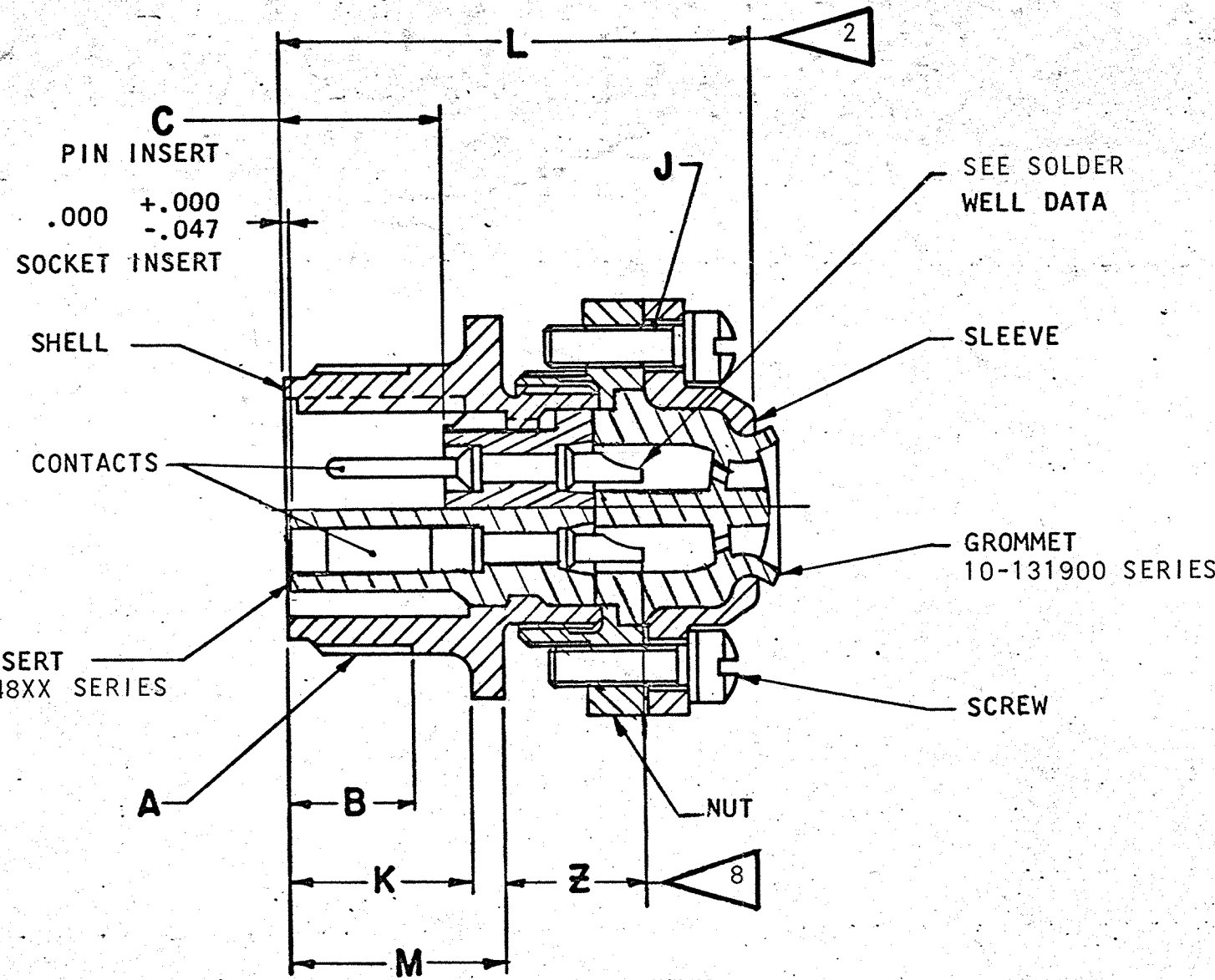
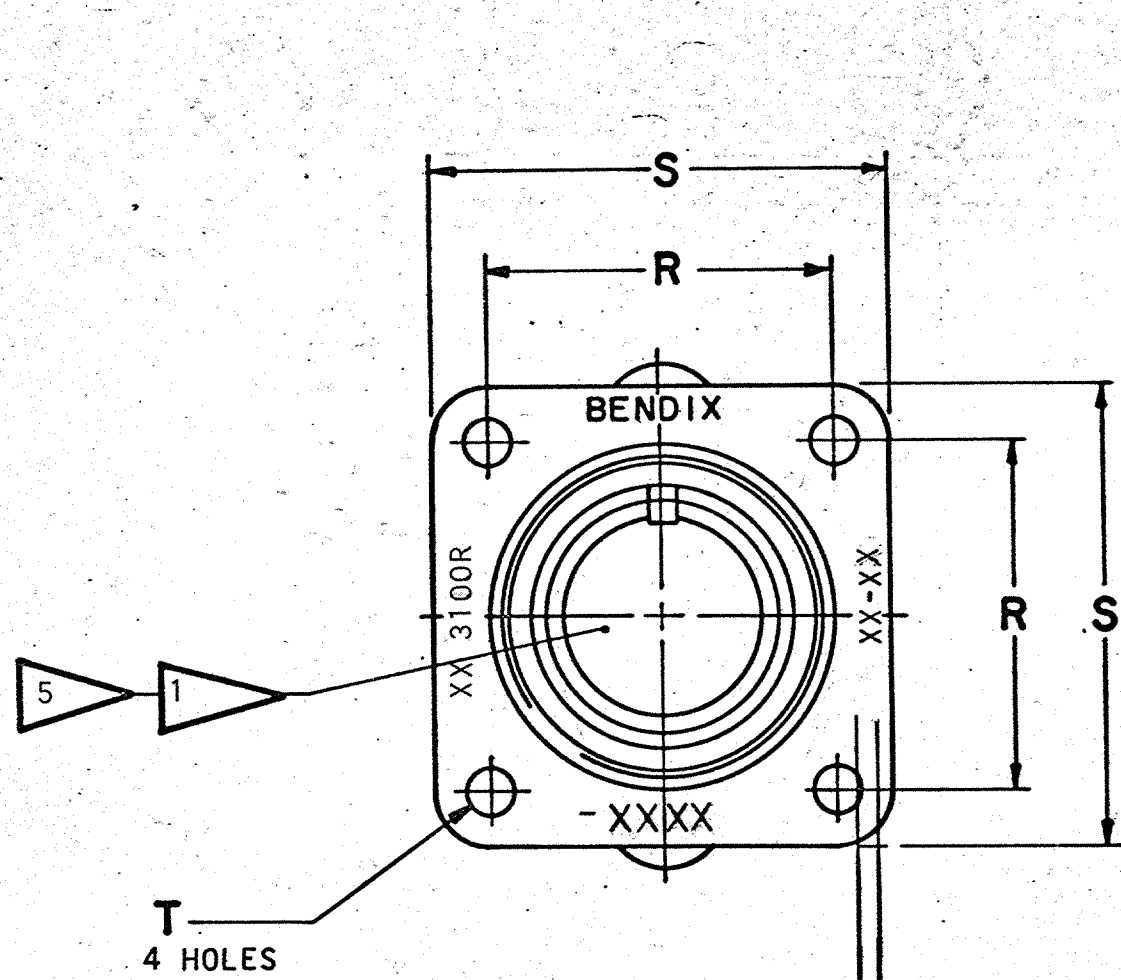

15 3 STAMP "BENDIX" & SM NO. PER 9-2811
EXAMPLE: BENDIX SM3100R-18-54P
OR

14 3 STAMP "BENDIX", DATE CODE (9-3895) & MS NO. PER 9-2811
EXAMPLE: BENDIX-7539 MS3100R-18-1P

.062
4 PLACES

STANDARD SOLDER WELL DATA						SPECIAL SOLDER WELL DATA			THERMOCOUPLE	
CONTACT SIZE	0	4	8	12	16	8 FOR NO. 6 WIRE	12 FOR NO. 10 WIRE	16 FOR NO. 12 WIRE	12	16
WELL DIA	.469 ^{+.005} -.003	.332 ^{+.005} -.003	.209 ^{+.004} -.002	.116 ^{+.004} -.002	.078 ^{+.004} -.002	.250±.003	.152 ^{+.004} -.002	.109 ^{+.004} -.001	.125 ^{+.004} -.002	.094 ^{+.004} -.002
WELL DEPTH	^{+.031} -.000	.625	.625	.500	.375	.500	.250	.188	.250	.188

FIND NO.	QTY REQD	CODE IDENT	PART NUMBER	DESCRIPTION	NOTE REF
PARTS LIST					
UNLESS OTHERWISE SPECIFIED LINEAR DIMENSIONS ARE IN INCHES. TOLERANCES: .XXX ± .010, .XX ± .03, X ± .1, ANGLES ± 2° OTHER STANDARDS PER 9-3800 AND MIL-D-1000. NOTE REF			SIGNATURES	DATES	The Bendix Corporation Electrical Components Division Sidney, New York
MATERIAL SPEC			PREPARED JOYCE	9-26-58	
			CHECKED <i>Whist</i>	10-2-73	
PROCESS SPEC TEST 9-3106-1 ASSY 9-3238-1 9-2437 9-2811 9-3895			APPROVED <i>E. Shepher</i>	12-7-72	
			APPROVED <i>W. M. Harmon</i>	10-4-73	
TITLE:				CONNECTOR, ELECTRICAL RECEPTACLE, TYPE MS-R, SM-R () FW	
SIZE		CODE IDENT NO.		10-190008 THRU 10-190050	
SCALE NONE		SEE PARTS LIST		REF	
				SHEET 1 OF 2	

SEE SHEET 2. NOTES:

4

3

2

1

ASSEMBLY NUMBER	14 SM OR MS NO.	SHELL	NUT	SLEEVE	SCREW (2 REQD)	A THREAD (PLATED) CLASS 2A	B MIN FULL THD	C ±.031	J THREAD REF CLASS 2	K +.010 -.000	L MAX	M +.020 -.010	P DIA MAX	R ±.005	S	T DIA +.004 -.002	Z MAX	KK DIA MAX
10-190008-	3100R-8S -	10-37260-8	10-130028 -83	10-130029 -83	10-101152 -83	.500 -28UNEF	.391	.484	6-32UNC	.562	1.588	.672	.557	.594	.875	.120	.472	.959
10-190010-	-10S-	-10	-103	-103		.625 -24UNEF	.391	.484	6-32UNC	.562	1.588	.672	.682	.719	1.000	.120		1.026
10-190011-	-10SL-	-11	-123	-123		.625 -24UNEF							.807	.719	1.000			1.120
10-190012-	-12S-	-12	-123	-123		.750 -20UNEF	.450							.812	1.094			
10-190013-	-12-	-13	-133	-123		.750 -20UNEF	.625	.672		.750	1.931	.860		.812	1.094		.672	
10-190014-	-14S-	-14	-143	-143		.875 -20UNEF	.450	.484		.562	1.588	.672	.932	.906	1.188		.472	1.307
10-190015-	-14-	-15	-153	-143		.875 -20UNEF	.625	.672		.750	1.931	.860	.932	.906	1.188		.672	1.307
10-190016-	-16S-	-16	-163	-163		1.000 -20UNEF	.450	.484		.562	1.588	.672	1.057	.969	1.281		.472	1.432
10-190017-	-16-	-17	-173	-163		1.000 -20UNEF	.625	.672		.750	1.931	.860	1.057	.969	1.281		.672	1.432
10-190018-	-18-	-18	-183	-183		1.125 -18UNEF						.891	1.182	1.063	1.375		.691	1.557
10-190020-	-20-	-20	-203	-203	10-101151-83	1.250 -18UNEF			8-32UNC				1.291	1.156	1.500			1.744
10-190022-	-22-	-22	-223	-223		1.375 -18UNEF							1.432	1.250	1.625			1.869
10-190024-	-24-	-24	-243	-243	10-101151-93	1.500 -18UNEF				.812	2.009	.953	1.557	1.375	1.750	.147	.628	1.994
10-190028-	-28-	-28	-283	-283		1.750 -18UNS				.812	2.009	.953	1.807	1.562	2.000	.147		2.166
10-190032-	-32-	-32	-323	-323	10-101270-93	2.000 -18UNS			10-32UNF	.875	2.072	1.031	2.057	1.750	2.250	.173	.550	2.541
10-190036-	-36-	-36	-363	-363		2.250 -16UN							2.260	1.938	2.500			2.729
10-190040-	-40-	-40	-403	-403		2.500 -16UN							2.510	2.188	2.750			2.979
10-190041/50		NOT AVAILABLE																

D

D

C

C

B

B

A

A

- 8. INCREASE Z DIMENSION BY .312 FOR SIZE "0" CONTACT.
- 7. ALL LOCKWIRE HOLES ARE .045 DIA MIN.
- 6. SEE DRAWINGS 10-190608 THRU 10-190650 AND OTHERS FOR REQUIRED MATING PLUG ASSEMBLIES.
- 5. INSERTS AND CONTACTS ARE NOT REMOVABLE.
- 4. TO COMPLETE ASSEMBLY NO., SM NO. OR MS NO., ADD APPLICABLE INSERT ARRANGEMENT SUFFIX TO BASE NUMBERS LISTED ABOVE. (FOR ALTERNATE ARRANGEMENTS, REFER TO 9-2437).
- 3. SEE WORK ORDER FOR PERMISSIBLE ADDITIONAL OR ALTERNATE STAMPING.
- 2. DIMENSION INDICATES FINAL INSTALLATION. FOR STORAGE AND SHIPPING, NUT AND SLEEVE MUST BE LOOSELY COUPLED.
- 1. FOR CONTACT SIZE, SPACING AND SERVICE RATING, SEE DRAWINGS MS33680/MS33693 & L-11908-() THRU L-11948-().

- 15. CONNECTOR ASSEMBLIES 10-190001-50/-99 THRU 10-190050-50/-99, EXCEPT THOSE LISTED IN NOTE 14, ARE STAMPED WITH SM NO.
- 14. CONNECTOR ASSEMBLIES 10-190008-1/-49 THRU 10-190050-1/-49 AND 10-190036-52, 10-190040-56 AND 10-190040-62 ARE STAMPED WITH MS NO.
- 13. PACKAGE PER PRODUCTION PROCESS SHEET.
- 12. SHIP CONNECTOR, WITH SEALING PLUGS UNASSEMBLED, MS STAMPED CONNECTORS ONLY.
- 11. ALL UNUSED GROMMET HOLES MUST BE FILLED WITH APPROPRIATE SIZE SEALING PLUGS. SEALING PLUGS ARE PART OF MS STAMPED ASSEMBLIES ONLY.
- 10. FOR COMPONENT PART NUMBERS, QUANTITIES, AND RELEASE STATUS OF THE DESIRED UNIT, SEE SEPARATE PARTS LIST.
- 9. UNITS ILLUSTRATED MEET THE MATERIAL & FINISH REQUIREMENTS OF MIL-C-5015.

NOTES:

SIZE	CODE IDENT NO.	10-190008 THRU
C	77820	10-190050

REV SYM	A	B	C	D								SCALE	WT	REF	SHEET	2
---------	---	---	---	---	--	--	--	--	--	--	--	-------	----	-----	-------	---

TAB.

10-190008/50

