

REV.	DATE	ECR NO.	DESCRIPTION
A	03/06/05	XXXXXX	MODIFY PLATING SPECS.
B	10/27/05	XXXXXX	MODIFY PLATING SPECS. TO BRT. TIN
C	03/16/06	XXXXXX	CHANG CABLE DESCRIPTION TO RG 179/U
D	04/06/10	XXXXXX	ADDED THD DOUBLE D MOUNTING HOLE

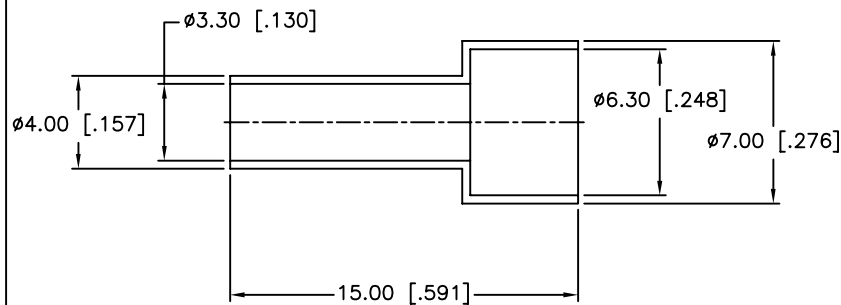
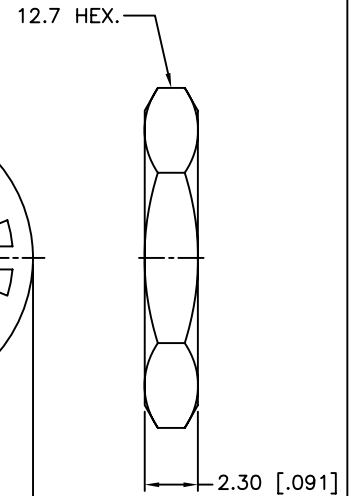
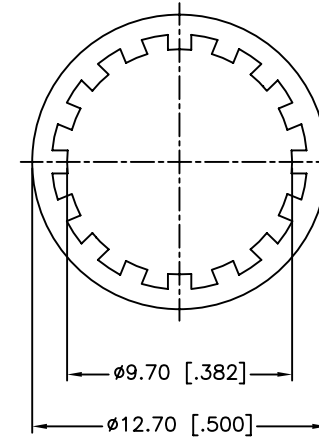
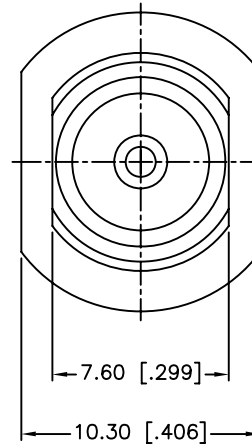
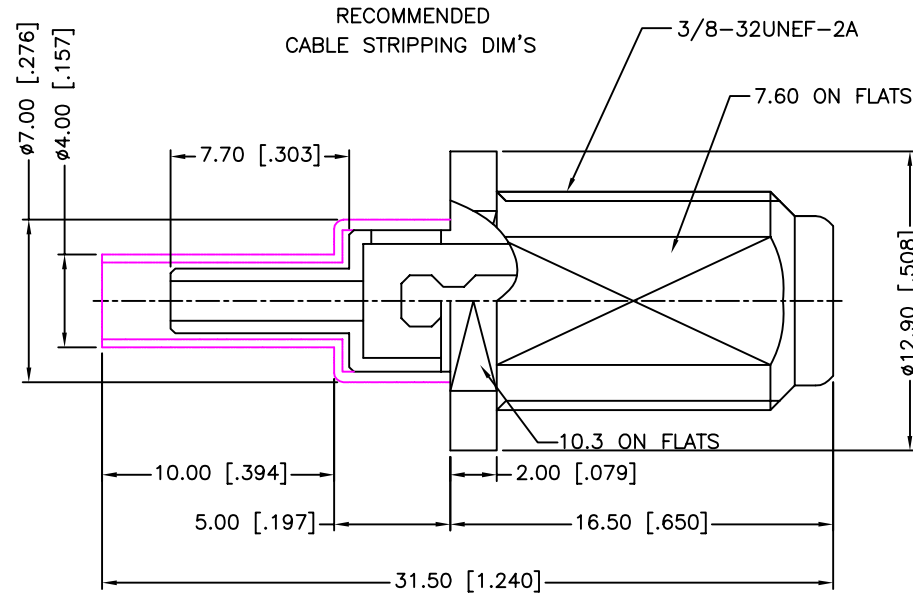

1. CRIMPED FERRULE  
HEX CRIMP SIZE .128"
2. CONTACT PIN TO SOLDER
3. MAX. PANEL THICKNESS=4.5mm

7	FERRULE	BRASS	BRIGHT TIN	1
6	HEX NUT	BRASS	BRIGHT TIN	1
5	LOCK WASHER	BRASS	BRIGHT TIN	1
4	INSULATOR	P.P	NATURAL	1
3	CONTACT PIN	BRASS	BRIGHT TIN	1
2	INSULATOR	P.P	NATURAL	1
1	BODY	BRASS	BRIGHT TIN	1
	DESCRIPTION	MATERIAL	FINISH	QTY

UNLESS OTHERWISE SPECIFIED DIMENSIONS ARE IN MILLIMETERS. DIMENSIONS IN [ ] ARE IN INCHES AND FOR CUSTOMER REFERENCE ONLY.

UNLESS OTHERWISE SPECIFIED TOLERANCES FOR MILLIMETERS ARE:  
 0.5 - 8mm ± 0.20mm  
 8 - 30mm ± 0.40mm  
 30 - 120mm ± 0.50mm

UNLESS OTHERWISE SPECIFIED TOLERANCES FOR INCHES ARE:  
 .020 - .315 = ± 0.007"  
 .315 - 1.180 = ± 0.015"  
 1.180 - 4.724 = ± 0.020"

DO NOT SCALE DRAWING

APPROVALS	DATE
DRAWN M.ZHANG	04/06/10
CHECKED	
ISSUED	
SHEET 1 OF 1	
CAD FILE C:/CONNEX/222114-10.DWG	

<b>Amphenol Connex</b>			
PART DESCRIPTION <b>F BULKHEAD CRIMP JACK (FOR RG-179/U WITH NUT AND WASHER)</b>			
PART NO. <b>222114-10</b>			
DWG. NO.	222114-10.DWG	REV.	D
SIZE	A	SCALE	NA