

# HZ0603C601R-10

**UNCONTROLLED DOCUMENT**

PHYSICAL DIMENSIONS:

A	1.60 [.063]	+ 0.15	-.006	[.006]
B	0.80 [.031]	+ 0.15	-.006	[.006]
C	0.80 [.031]	+ 0.15	-.006	[.006]
D	0.36 [.014]	+ 0.15	-.006	[.006]

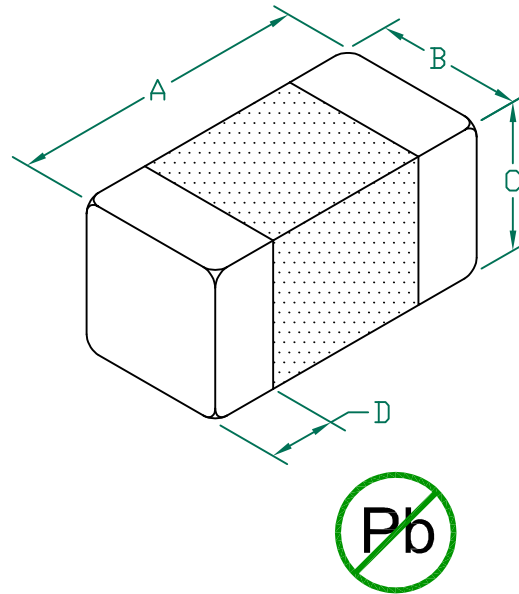

ELECTRICAL CHARACTERISTICS:			
	Z @ 100MHz ( $\Omega$ )	DCR ( $\Omega$ )	Rated Current
Nominal	600		
Minimum	450		
Maximum	750	0.45	300 mA

NOTES: UNLESS OTHERWISE SPECIFIED

1. TAPED AND REELED per CURRENT EIA SPECIFICATIONS 7" REELS, 4000 PCS/REEL.
2. TERMINATION FINISH IS 100% TIN.
3. COMPONENTS SHOULD BE ADEQUATELY PREHEATED BEFORE SOLDERING.
4. OPERATING TEMP. RANGE:  $-40^{\circ}\text{C} \sim +125^{\circ}\text{C}$  (INCLUDING SELF-HEATING)

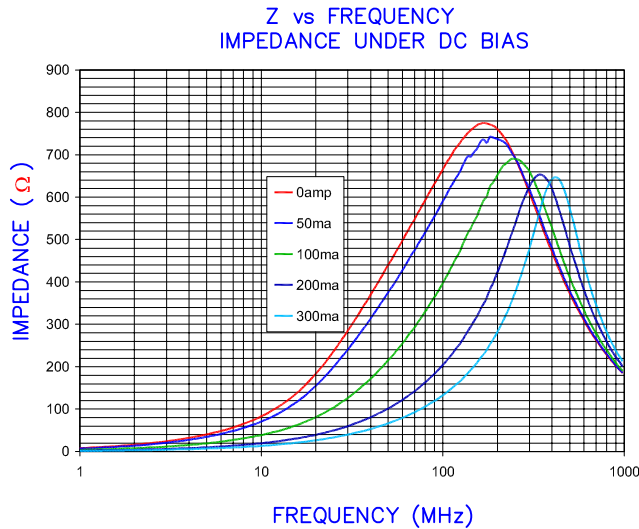

LAND PATTERNS FOR REFLOW SOLDERING

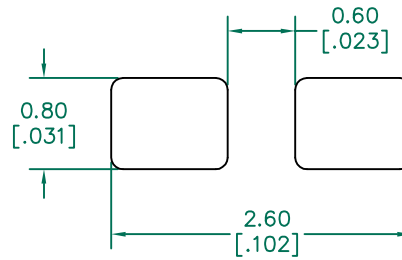

(For wave soldering, add 0.762 (.030) to this dimension)

RECOMMENDED SOLDERING CONDITIONS

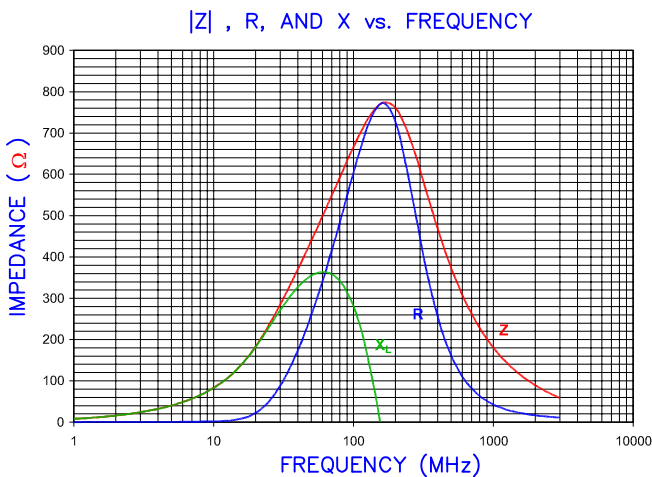
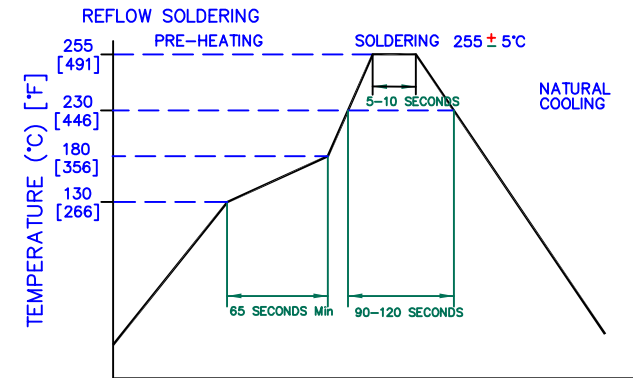

DIMENSIONS ARE IN mm [INCHES].				This print is the property of Laird Tech. and is loaned in confidence subject to return upon request and with the understanding that no copies shall be made without the written consent of Laird Tech. All rights to design or invention are reserved.				
D	ADD OPERATING TEMPERATURE UPDATE LAIRD LOGO AND REFLOW CURVE	08/05/13	QU	PROJECT/PART NUMBER: HZ0603C601R-10		REV D	PART TYPE: CO-FIRE	DRAWN BY: TMB
C	CHANGE SOLDERING TEMPERATURE FROM 250	07/12/10	JUN	DATE: 03/26/04		SCALE: NTS	SHEET: 2 of 2	
B	UPDATE COMPANY LOGO ADD ROHS	02/27/08	JRK	DATE: 03/26/04		SCALE: NTS	SHEET: 2 of 2	
A	ORIGINAL DRAFT	03/26/04	TMB	DATE: 03/26/04		SCALE: NTS	SHEET: 2 of 2	
REV	DESCRIPTION	DATE	INT	CAD # HZ0603C601R-10-D		TOOL # -	SHEET: 2 of 2	