



PRODUCT SPECIFICATION

Milligrd BMI 2mm Pitch Vertical Header

1.0 SCOPE

This specification covers the performance requirements for 2mm pitch, Vertical Header

2.0 PRODUCT DESCRIPTION

2.1 PRODUCT NAME AND SERIES NUMBER (S)

Product Name

MILLIGRID 2MM PITCH VERTICAL HEADER

Series Number

151013

This series mates with Molex Milligrd 2mm Wire to Board Connector Crimp Receptacle Housing, 51110-**52 and 51110-**60 series and Crimp Terminal, 50394 series.

2.2 DIMENSIONS, MATERIALS, PLATINGS AND MARKINGS

See Sales Drawing, SD-151013-0001 for information on dimensions, materials platings and markings.

2.3 SAFETY AGENCY APPROVALS

UL Number: E29179

CSA Number: 1585720 (LR19980)

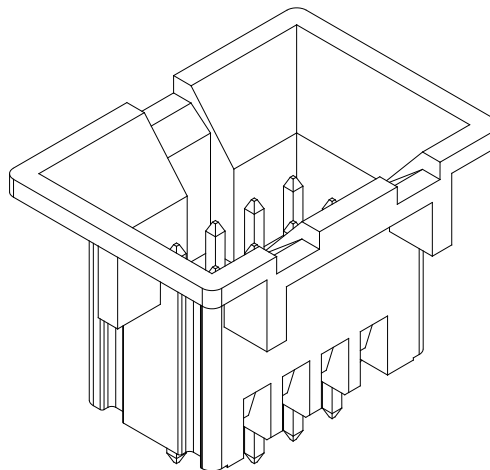

REVISION: A	ECR/ECN INFORMATION: EC No: S2015-0674 DATE: 2014/12/16	TITLE: MILLIGRID BMI 2MM PITCH VERTICAL HEADER	SHEET No. 1 of 5
DOCUMENT NUMBER: PS-151013-0001	CREATED / REVISED BY: GMENARLY 2015/03/05	CHECKED BY: CGOH 2015/03/26	APPROVED BY: VICTOR LIM 2015/03/26



PRODUCT SPECIFICATION

3.0 APPLICABLE DOCUMENTS AND SPECIFICATIONS

See Sales Drawing SD-151013-0001, IPC/WHMA-A-620AS and other sections of this Specification for the necessary referenced Documents and Specifications.

4.0 RATINGS

4.1 VOLTAGE : 125 V Max.

4.2 CURRENT : 2.00 Amps Max

4.3 TEMPERATURE

Operating	0°C to +75°C
Non-operating	-40°C to +105°C

5.0 PERFORMANCE

5.1 ELECTRICAL REQUIREMENTS

ITEM	DESCRIPTION	TEST CONDITION	REQUIREMENT
1	Contact Resistance (Low Level)	Mate connectors: apply a maximum voltage of 20 mV and a current of 100 mA Per EIA-364-23	40 milliohms Max.
2	Insulation Resistance	Unmate connectors: apply 500 VDC for 1 minute, measure the insulation resistance between adjacent terminals Per EIA 364-21	1000 Megaohms Min.
3	Dielectric Withstanding Voltage	Unmate connectors: apply 1250 VAC for 1 minute between adjacent terminals Per EIA 364-20	No breakdown
4	Temperature Rise (via Current Cycling)	Mate connectors: measure the temperature rise at the rated current after: 1.) 96 hours (steady state) 2.) 240 hours (45 minutes ON and 15 minutes OFF per hour). 3.) 96 hours (steady state)	Temperature rise: +30°C Max.

REVISION: A	ECR/ECN INFORMATION: EC No: S2015-0674 DATE: 2014/12/16	TITLE: MILLIGRID BMI 2MM PITCH VERTICAL HEADER	SHEET No. 2 of 5
DOCUMENT NUMBER: PS-151013-0001	CREATED / REVISED BY: GMENARLY 2015/03/05	CHECKED BY: CGOH 2015/03/26	APPROVED BY: VICTOR LIM 2015/03/26



PRODUCT SPECIFICATION

5.2 MECHANICAL REQUIREMENTS

ITEM	DESCRIPTION	TEST CONDITION	REQUIREMENT
5	Pin Retention Force	Apply an axial load on the terminal in the housing to dislodge the terminals from the connector at a rate of 12.5mm per minute	8.5 N Min. per pin (initial)
6	Durability	Mate connectors 25 cycles with maximum rate of 10 cycles per minute Per EIA-364-09	20 milliohms Max. (change from initial) No evidence of physical Damage
7	Vibration	Mate connectors : Test Condition per EIA 364-28, test condition VII, test condition letter D (15 min. in each of 3 mutual perpendicular directions. Both mating halves should be rigidly fixed so as not to contribute to the relative motion of one contact against another.	10 milliohms Max. (change from initial) & Discontinuity < 1 microsecond
8	Mechanical Shock	Mate connectors and shock at 50 g's with ½ sine wave (11 milliseconds) shocks in the ± X, ± Y, ± Z axes (18 shocks total).	10 milliohms Max. (change from initial) & Discontinuity < 1 microsecond

5.3 ENVIRONMENT REQUIREMENTS

ITEM	DESCRIPTION	TEST CONDITION	REQUIREMENT										
9	Solderability	Solder Time: 5 +/-0.5 secs. Solder Temperature: 260+/- 5°C Steam aging for 8hours	Dipped portion should have 95% continuous new solder coating coverage										
10	Resistance to Soldering Heat	Refer to Section 8.0 for soldering profile	No damage in appearance of the connector										
11	Thermal Shock	Mate connectors; expose to 5 cycles of: <table border="0"> <tr> <td><u>Temperature °C</u></td> <td><u>Duration (Minutes)</u></td> </tr> <tr> <td>-55+0/-3</td> <td>30</td> </tr> <tr> <td>+25±10</td> <td>5 MAXIMUM</td> </tr> <tr> <td>+85+3/-0</td> <td>30</td> </tr> <tr> <td>+25±10</td> <td>5 MAXIMUM</td> </tr> </table> Per EIA 364-32 condition I	<u>Temperature °C</u>	<u>Duration (Minutes)</u>	-55+0/-3	30	+25±10	5 MAXIMUM	+85+3/-0	30	+25±10	5 MAXIMUM	20 milliohms Max. (change from initial) & Visual: No Damage
<u>Temperature °C</u>	<u>Duration (Minutes)</u>												
-55+0/-3	30												
+25±10	5 MAXIMUM												
+85+3/-0	30												
+25±10	5 MAXIMUM												
12	Temperature Life	Mate connectors; expose to: 96 hours at 105 ± 2°C Per EIA 364-17	20 milliohms Max. (change from initial]) & Visual: No Damage										

<u>REVISION:</u> A	<u>ECR/ECN INFORMATION:</u> EC No: S2015-0674 DATE: 2014/12/16	<u>TITLE:</u> MILLIGRID BMI 2MM PITCH VERTICAL HEADER	<u>SHEET No.</u> 3 of 5
<u>DOCUMENT NUMBER:</u> PS-151013-0001	<u>CREATED / REVISED BY:</u> GMENARLY 2015/03/05	<u>CHECKED BY:</u> CGOH 2015/03/26	<u>APPROVED BY:</u> VICTOR LIM 2015/03/26



PRODUCT SPECIFICATION

ITEM	DESCRIPTION	TEST CONDITION	REQUIREMENT
14	Humidity (Cyclic)	24 cycles at temperature 25 ± 3°C at 80 ± 3% relative humidity and 65 ± 3°C at 50 ± 3% relative humidity; dwell time of 1.0 hour; ramp time of 0.5 hours. Dwell times start when the temperature and humidity have stabilized within the specified levels. Per EIA-364-31	Dielectric Withstanding Voltage: No Breakdown at 500 VAC & Insulation Resistance: 1250 Megohms Min. & Visual: No Damage

6.0 PACKAGING

Refer to Packing Specification, PK-151013-0001 for packaging details.

7.0 TEST SEQUENCES

Test Group →	A	B	C	D	E	F	G
Test or Examination ↓							
Examination of the connector(s)	1	1,5	1	1,8	1	1	1
Contact Resistance (Low Level) (LLCR)				3,5, 7	3,5, 7	3,5, 7,9	
Insulation Resistance	3,6						
Dielectric Withstanding Voltage	4,7						
Temperature Rise (via Current Cycling)		4					
Pin Retention Force in housing			2				
Durability		3		4	4	4	
Vibration						6	
Mechanical Shock						8	
Humidity (cyclic)	5						
Temperature Life				6			
Thermal Shock					6		
Resistance to Soldering Heat	2	2		2	2	2	
Solderability							2

REVISION: A	ECR/ECN INFORMATION: EC No: S2015-0674 DATE: 2014/12/16	TITLE: MILLIGRID BMI 2MM PITCH VERTICAL HEADER	SHEET No. 4 of 5
DOCUMENT NUMBER: PS-151013-0001	CREATED / REVISED BY: GMENARLY 2015/03/05	CHECKED BY: CGOH 2015/03/26	APPROVED BY: VICTOR LIM 2015/03/26



PRODUCT SPECIFICATION

8.0 SOLDERING PROFILE

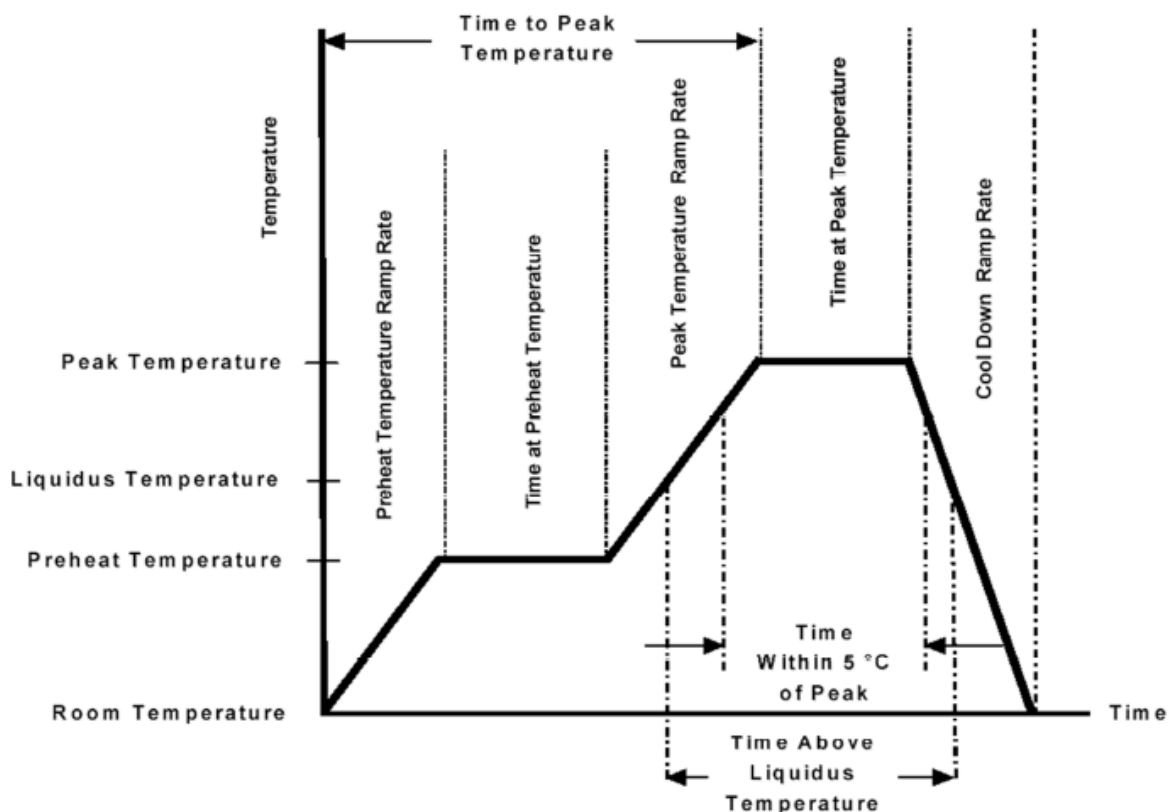

Description	Requirement
Average Ramp Rate	3°C/sec Max
Preheat Temperature	150°C Min to 200°C max
Preheat Time	60 to 180sec
Ramp to Peak	3°C/sec max
Time over Liquidus (217°C)	60 to 150 sec
Peak Temperature	260 +0/-5°C
Time within 5°C of Peak	20 to 40sec
Ramp - Cool Down	6°C/sec max
Time 25°C to Peak	8min Max

REVISION: A	ECR/ECN INFORMATION: EC No: S2015-0674 DATE: 2014/12/16	TITLE: MILLIGRID BMI 2MM PITCH VERTICAL HEADER	SHEET No. 5 of 5
DOCUMENT NUMBER: PS-151013-0001	CREATED / REVISED BY: GMENARLY 2015/03/05	CHECKED BY: CGOH 2015/03/26	APPROVED BY: VICTOR LIM 2015/03/26