

| LOC | | DIST | | REVISIONS | | | |
|-----|----|------|---------|--------------|---------|-----|------|
| FT | 64 | TR | LYR | DESCRIPTION | DATE | DWN | APVD |
| | | D | REV PER | 063C-0104-01 | 19JUL01 | RB | JO |

- RECEPTACLE ACCEPTS AN 0.20-0.36 [.008-.014] THK I.C. LEAD.
- TWO 0.00076 [.000030] MIN THK GOLD STRIPES IN CONTACT AREA, TIN-LEAD ON CONTACT LEGS, BALANCE OF CONTACT NICKEL PLATED.

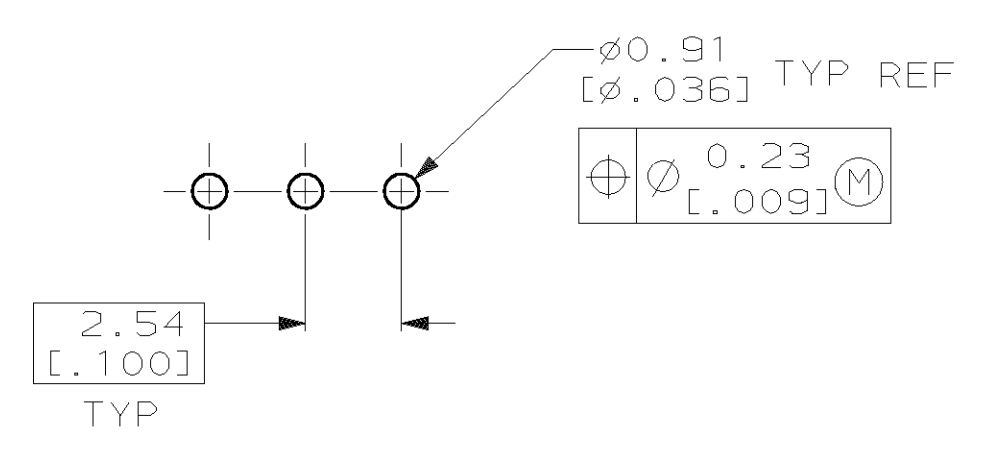

RECOMMENDED MOUNTING HOLE PATTERN

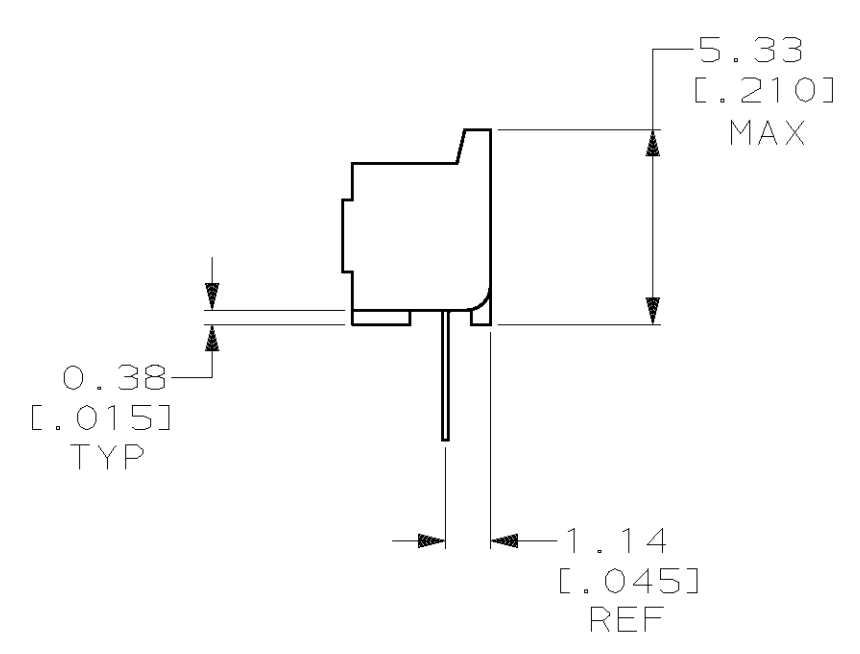
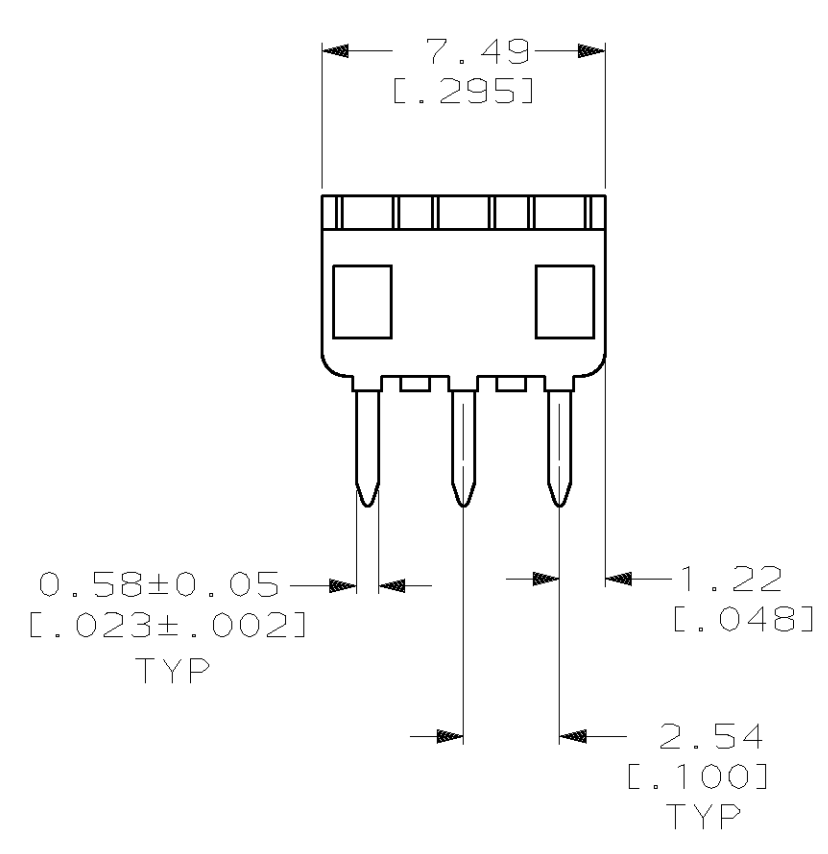
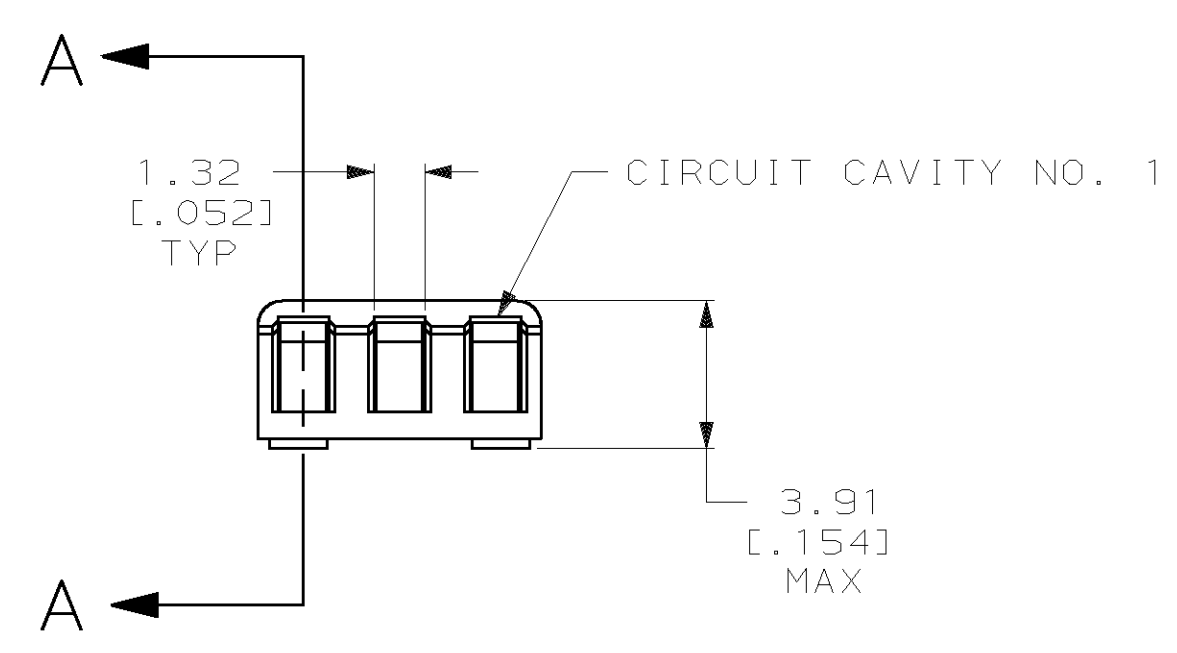
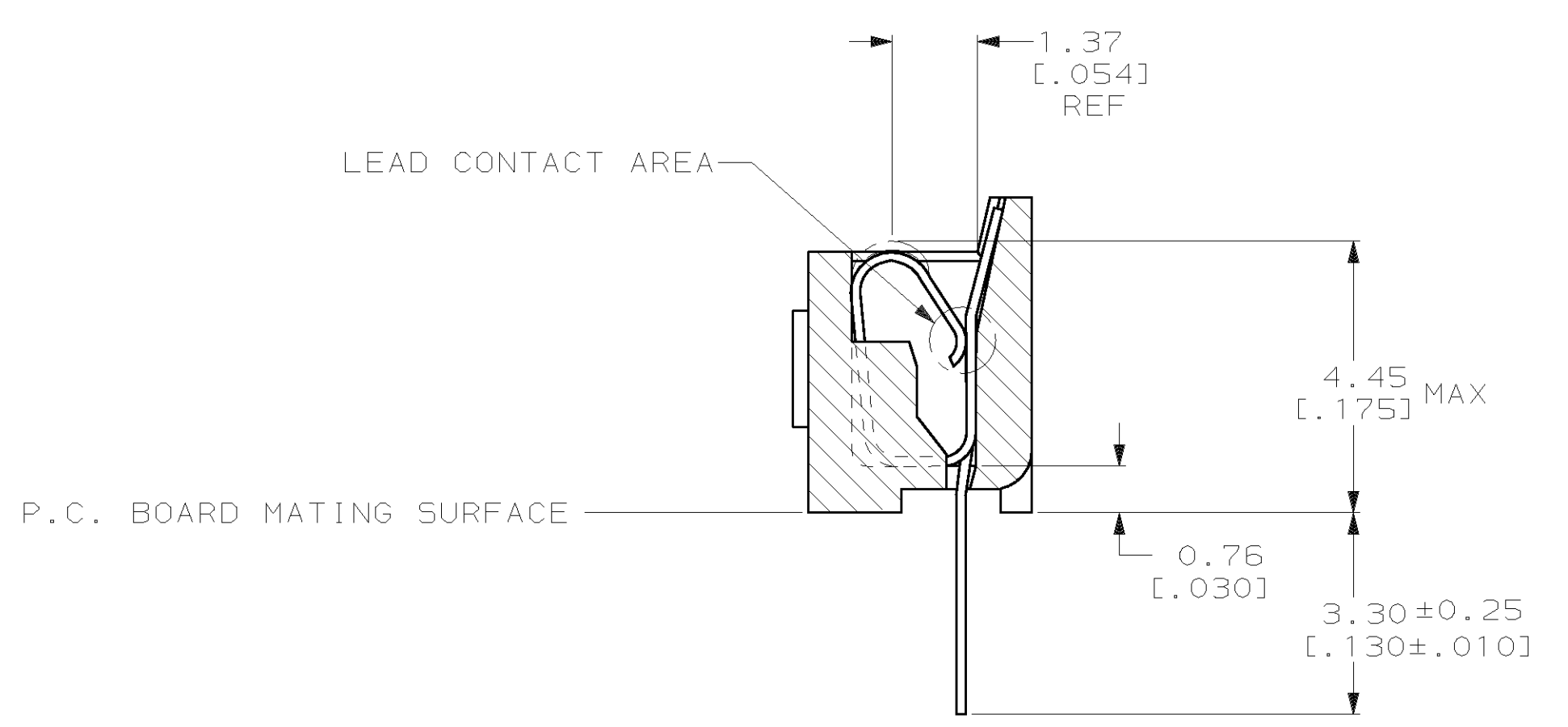

SECTION A-A
 ROTATED 90° CW
 SCALE 10:1

| | | | | |
|----------|----------------|---------------|--|----------|
| OBSOLETE | TINNED | PHOS.BRZ. | GLASS-FILLED THERMOPLASTIC, 94V-0, BLACK | 382437-3 |
| | | BE.CU. | GLASS-FILLED THERMOPLASTIC, 94V-0, BLACK | 382437-2 |
| | TINNED | BE.CU. | GLASS-FILLED THERMOPLASTIC, 94V-0, BLACK | 382437-1 |
| | CONTACT FINISH | CONTACT MAT'L | HOUSING MATERIAL | PART NO. |

THIS DRAWING IS A CONTROLLED DOCUMENT.

| | | | | | |
|---------------------------|--|-------------------------------|---------------------------------------|--------------------------------|---|
| DIMENSIONS mm (INCHES) | TOLERANCES UNLESS OTHERWISE SPECIFIED. | DWN K. SALMON 16 JAN 90 | CHK R. MILLER 16 JAN 90 | APVD R. PRIDDY 25 JAN 90 | NAME AMP Incorporated Harrisburg, PA 17105-3608 |
| 0 PLC ±- | 1 PLC ±- | PRODUCT SPEC | SOCKET ASSY, SIP, 3 POS, DIPLOMATE DL | | |
| 2 PLC ±0.13 (.005) | 3 PLC ±- | APPLICATION SPEC | 108-1066 | | |
| 4 PLC ±- | ANGLES ±- | WEIGHT | 114-1049 | | |
| MATERIAL SEE TABLE | FINISH SEE TABLE | SCALE | A1 00779 C-382437 | | |
| CUSTOMER DRAWING | | SCALE | SHEET 1 OF 1 REV 0 | | |