

CODE NO.	CONTACT	A	B	C	D	E	F	G	H
CL683-0259-9-57	26	11.5	8.2	7.1	6	11.3	9.7	11.9	9.1
CL683-0274-2-57	30	12.5	9.2	8.1	7	12.3	10.7	12.9	10.1
CL683-0367-1-57	60	20	16.7	15.6	14.5	19.8	18.2	20.4	17.6
CL683-0399-8-57	70	22.5	19.2	18.1	17	22.3	20.7	22.9	20.1
CL683-0375-0-57	80	25	21.7	20.6	19.5	24.8	23.2	25.4	22.6

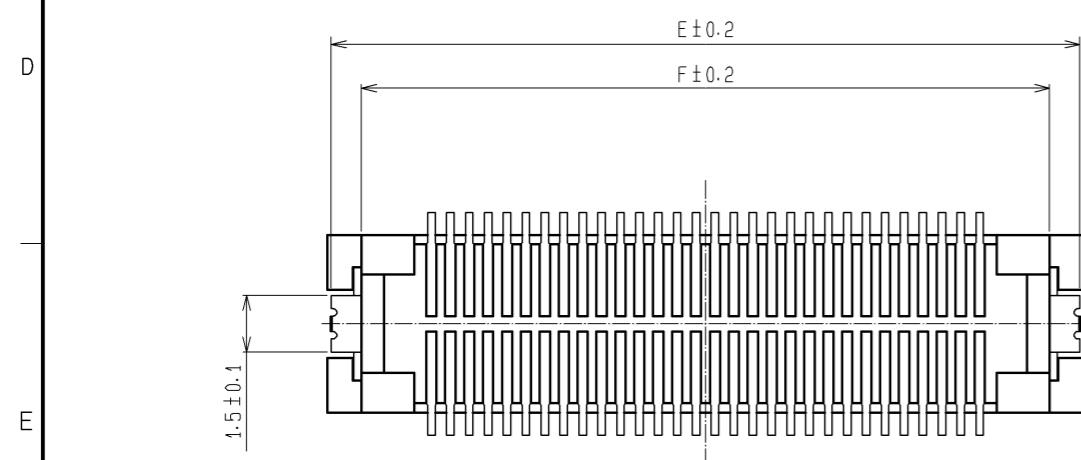

NOTES 1 : LEAD CO-PLANARITY INCLUDE REINFORCED METAL FITTINGS SHALL BE 0.1mm MAX.
 2 IF THE RESIST PROCESSING HAS NOT MADE, IT HAS POSSIBILITY THAT THE TERMINAL TOUCHES WITH AREA. PLEASE BE NOTED THIS POINT.

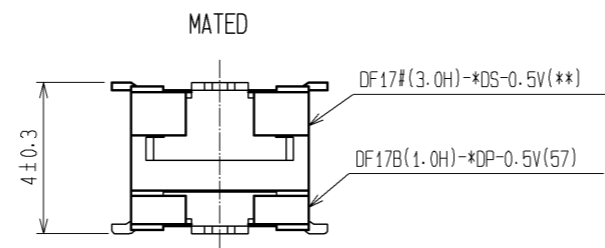

NO.	MATERIAL	FINISH . REMARKS	NO.	MATERIAL	FINISH . REMARKS
2	POLYAMIDE (PA6T)	WHITE BEIGE , UL94V-0	7	PS	CLEAR (REINFORCEMENT COLLAR)
1	PHOSPHER BRONZE	CONTACT AREA : GOLD PLATED 0.1μm min LEAD AREA : GOLD PLATED 0.02μm min UNDER PLATING : NICKEL 1μm min	6	PS	BLACK (PLASTIC REEL)
			5	POLYESTER	CLEAR (COVER TAPE)
			4	PS	CLEAR (EMBOSSED CARRIER TAPE)
			3	PHOSPHER BRONZE	TIN PLATED 1μm min UNDER PLATING : NICKEL 1μm min

UNITS	SCALE	COUNT	DESCRIPTION OF REVISIONS	DESIGNED	CHECKED	DATE
mm	5 : 1	2	DIS-H-007389	NT. SEKI	YH. MICHIDA	12. 11. 09

APPROVED	CHECKED	DESIGNED	DRAWN	DRAWING NO.	PART NO.	CODE NO.
KH. IKEDA	TS. MIYAZAKI	YH. MICHIDA	MS. SATO	EDC3-162767-77	DF17B(1.0H)-*DP-0.5V(57)	CL683-

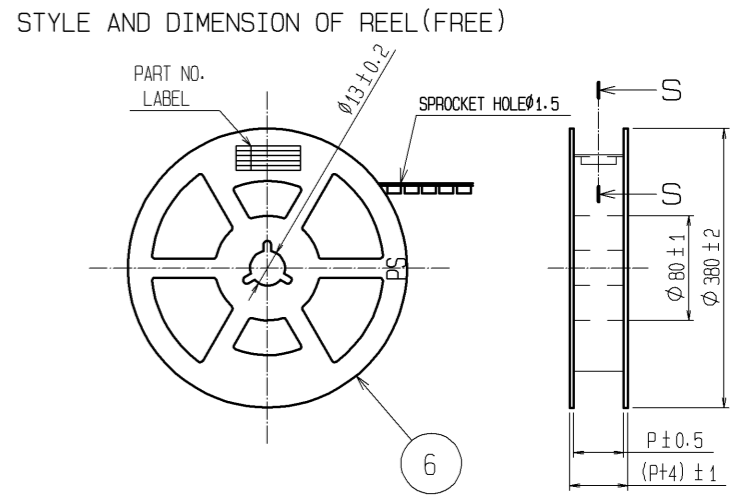
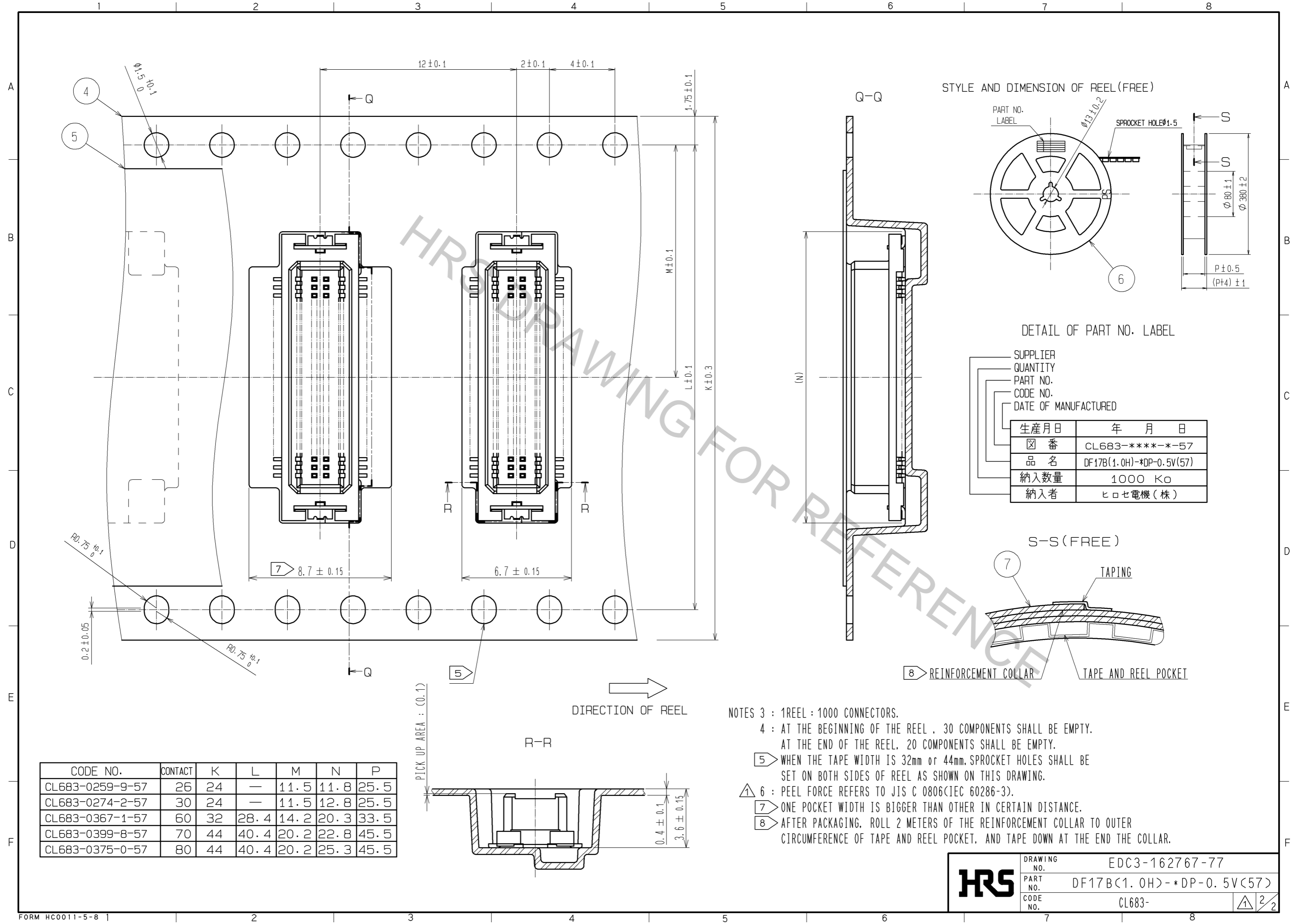

DETAIL OF PART NO. LABEL

SUPPLIER
 QUANTITY
 PART NO.
 CODE NO.
 DATE OF MANUFACTURED

生産月日	年 月 日
☒ 番	CL683-*****-57
品名	DF17B(1.0H)*DP-0.5V(57)
納入数量	1000 Ko
納入者	ヒロセ電機(株)

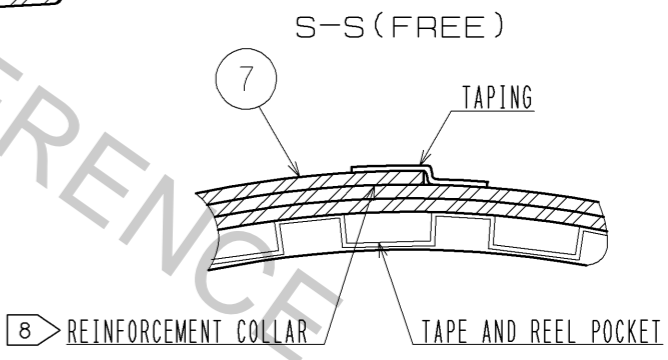

CODE NO.	CONTACT	K	L	M	N	P
CL683-0259-9-57	26	24	—	11.5	11.8	25.5
CL683-0274-2-57	30	24	—	11.5	12.8	25.5
CL683-0367-1-57	60	32	28.4	14.2	20.3	33.5
CL683-0399-8-57	70	44	40.4	20.2	22.8	45.5
CL683-0375-0-57	80	44	40.4	20.2	25.3	45.5

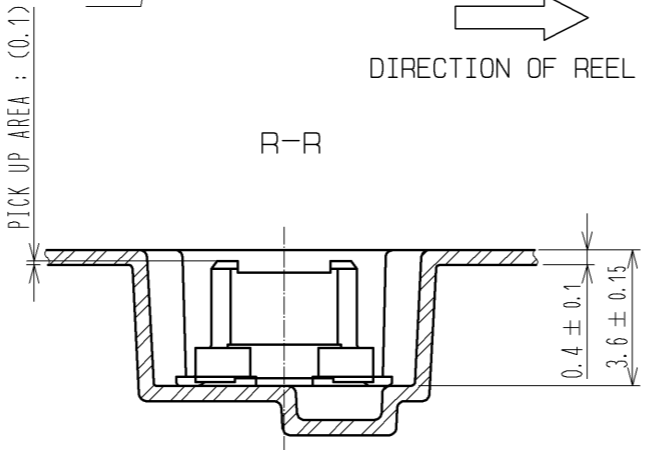

- NOTES 3 : 1 REEL : 1000 CONNECTORS.
 4 : AT THE BEGINNING OF THE REEL , 30 COMPONENTS SHALL BE EMPTY.
 AT THE END OF THE REEL, 20 COMPONENTS SHALL BE EMPTY.
 5 WHEN THE TAPE WIDTH IS 32mm or 44mm, SPROCKET HOLES SHALL BE SET ON BOTH SIDES OF REEL AS SHOWN ON THIS DRAWING.
 6 : PEEL FORCE REFERS TO JIS C 0806(IEC 60286-3).
 7 ONE POCKET WIDTH IS BIGGER THAN OTHER IN CERTAIN DISTANCE.
 8 AFTER PACKAGING, ROLL 2 METERS OF THE REINFORCEMENT COLLAR TO OUTER CIRCUMFERENCE OF TAPE AND REEL POCKET, AND TAPE DOWN AT THE END THE COLLAR.

HRS	DRAWING NO.	EDC3-162767-77
	PART NO.	DF17B(1.0H)*DP-0.5V(57)
	CODE NO.	CL683-
		2/2