

# Ready™ for XMEGA®

Best solution for fast and simple development of applications using ATxmega128A1 device. With special white plastic casing you can quickly turn your Ready for XMEGA project into a final product.



# TO OUR VALUED CUSTOMERS

I want to express my thanks to you for being interested in our products and for having confidence in MikroElektronika.

The primary aim of our company is to design and produce high quality electronic products and to constantly improve the performance thereof in order to better suit your needs.

A white handwritten signature in cursive script, appearing to read 'N. Matic', set against a dark teal background.

Nebojsa Matic  
General Manager

# Table of Contents

|                                    |    |                                 |    |
|------------------------------------|----|---------------------------------|----|
| Introduction                       | 4  | step 4 - Selecting .hex file    | 15 |
| Package Contains                   | 5  | step 5 - Uploading .hex file    | 15 |
| Key Features                       | 6  | step 6 - Progress bar           | 16 |
| 1. Power supply                    | 8  | step 7 - Finish upload          | 16 |
| 2. ATxmega128A1 Microcontroller    | 10 | Programing with JTAG programmer | 17 |
| Key microcontroller features       | 10 | Programing with PDI             | 18 |
| 3. Programming the microcontroller | 11 | 4. USB-UART                     | 20 |
| Programming with mikroBootloader   | 12 | 5. Prototyping area             | 21 |
| mikroBootloader software           | 12 | 6. Pin headers                  | 22 |
| Identifying device COM port        | 13 | 7. Reset button                 | 23 |
| step 1 - Choosing COM port         | 13 | 8. Piezo buzzer                 | 24 |
| step 2 - Establishing connection   | 14 | 9. Integrating with the casing  | 25 |
| step 3 - Browsing for .hex file    | 14 | 10. Dimensions                  | 26 |

# Introduction

Ready for XMEGA Board is the best solution for fast and simple development of various microcontroller applications. It comes with **ATxmega128A1**, and contains double-row smart headers for all available microcontroller ports. We have grouped pins according to their functions, so you have everything on the silkscreen. You don't even have to browse through the datasheet. Board also contains USB-UART module, prototyping area and a power supply circuit. Board is specially designed to fit into special white plastic casing so you can turn your XMEGA project into a final product.

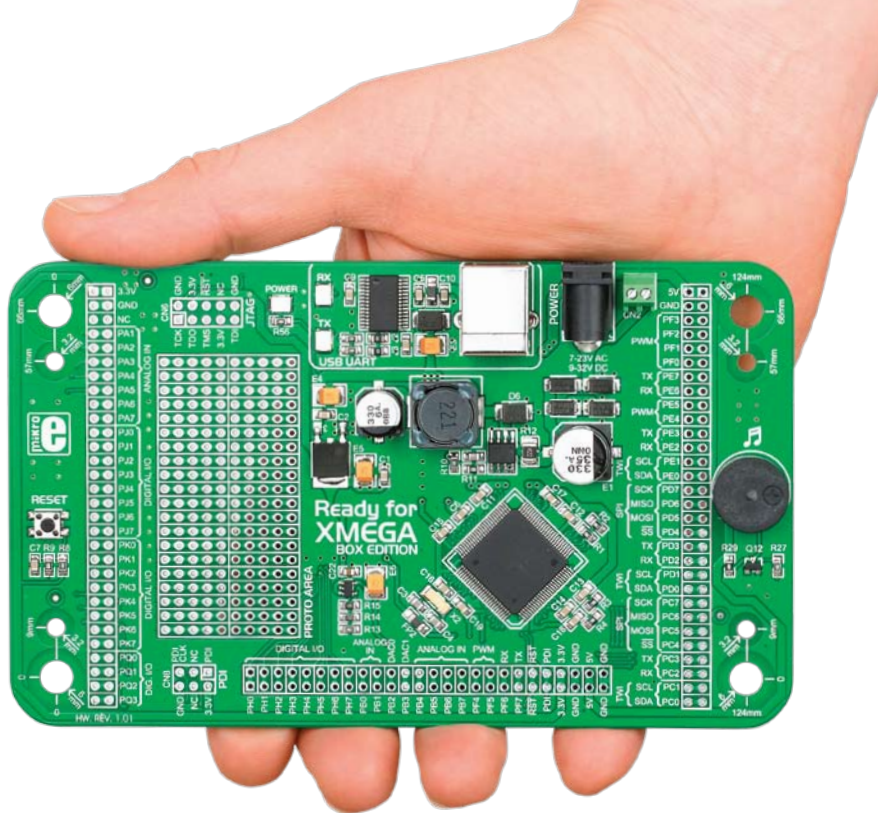

# Package Contains



- 01 Damage resistant protective box



- 02 Ready for XMEGA board with double row male pin headers



- 03 DVD with documentation and examples



- 04 Ready for XMEGA user's guide



- 05 Ready for XMEGA schematic



- 06 USB cable

# Key Features

## System Specification



### power supply

Via AC/DC connector 7-23V AC  
or 9-32V DC



### power consumption

50mA in idle state  
(when on-board modules are off)



### board dimensions

141 x 84mm (5.55 x 3.3 inch)



### weight

~67g (0.15 lbs)

JTAG connector 01

Power LED indicator 02

UART communication LEDs (RX, TX) 03

Power regulator 04

FTDI chip 05

USB UART connector 06

Power connector 07

Power screw terminals 08

Reset button 09

Double-row pin headers 10

PDI connection 11

Prototyping area 12

ATxmega128A1 microcontroller 13

Piezo Buzzer 14

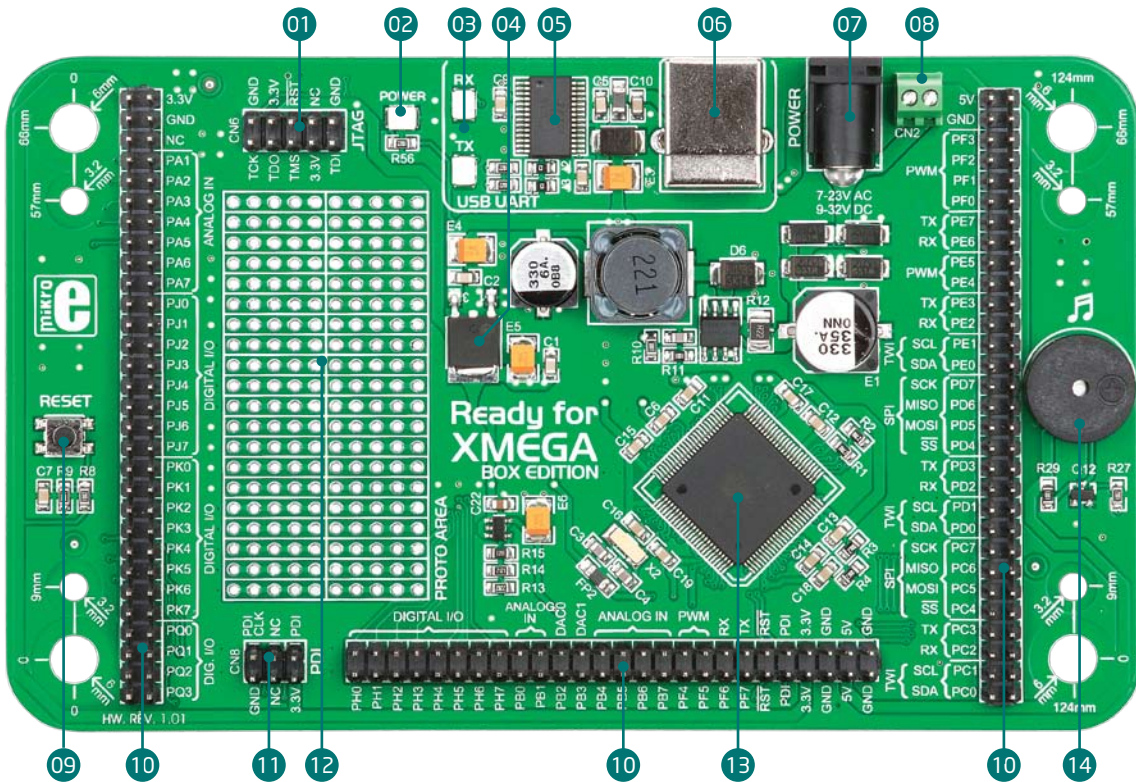



# 1. Power supply

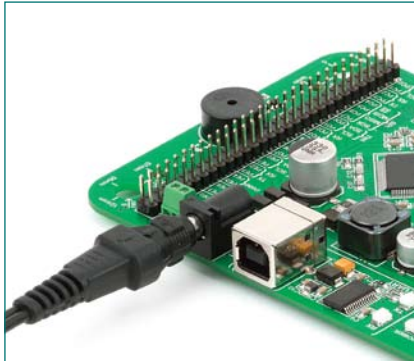

**Figure 1-1:**  
**AC/DC adapter power supply**  
**connected**

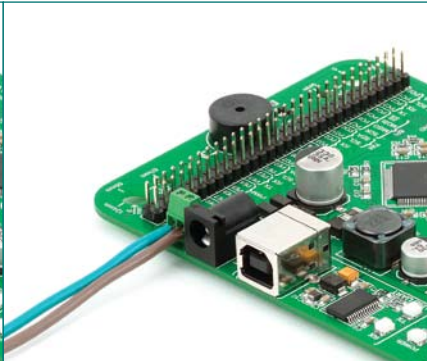

**Figure 1-2:**  
**laboratory power supply**  
**connected to screw terminals**

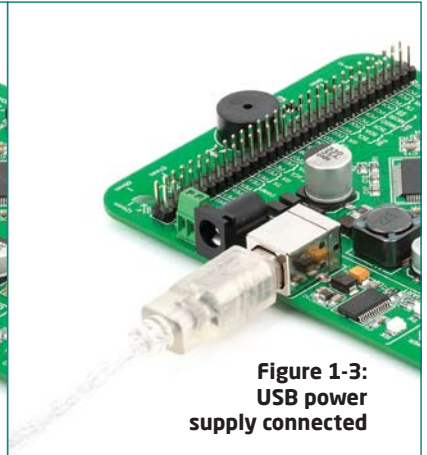

**Figure 1-3:**  
**USB power**  
**supply connected**

Ready for XMEGA board can be powered in two ways: via USB connection, or using external power sources such as adapters and laboratory power supplies. USB connection can provide up to 500mA of current which is more than enough for every on-board module and for operation of the microcontroller. If you decide to use external power supply, you can choose between AC/DC adapter connector or power screw terminals. Voltage values must be within **7-23V AC** or **9-32V DC** ranges. **Power LED (GREEN)** will indicate the presence of power supply. Use only one of suggested methods for powering the board.



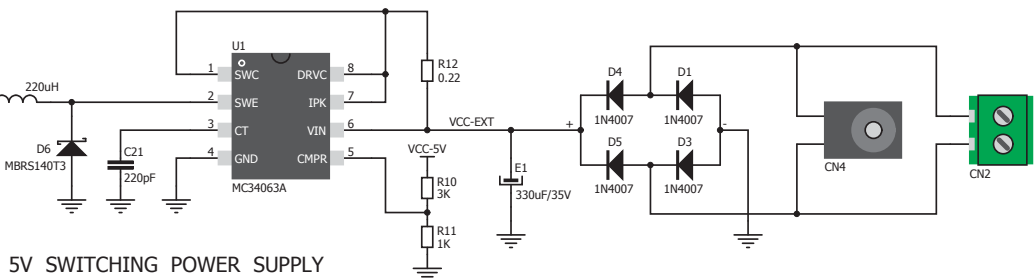
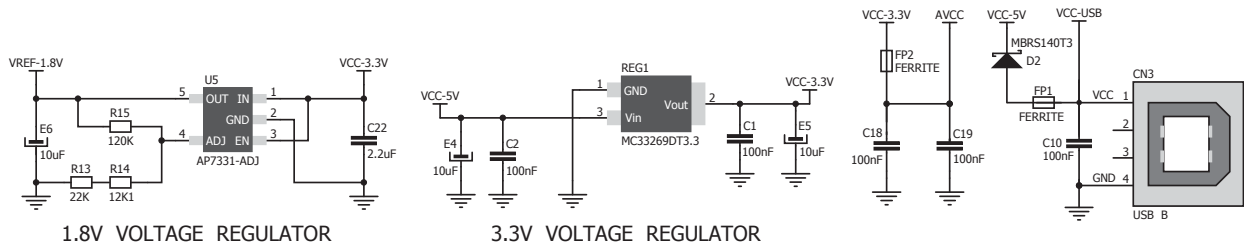

**Figure 1-4: Power supply schematics**

## 2. ATxmega128A1 microcontroller

Ready for XMEGA development system comes with the **ATxmega128A1** microcontroller. Having lots of MIPS power, flash and RAM, and rich set of integrated modules, ATxmega128A1 is ideal choice for both beginners and professionals.

### Key microcontroller features

- Up to **32 MIPS** Operation;
- 8/16-bit architecture;
- 128KB of Flash memory;
- 8KB of SRAM memory;
- 2048Bytes of EEPROM;
- 78 I/O pins;
- 32kHz RTC;
- 1.6V to 3.6V Operating Voltage (VCC);
- UART, SPI, TWI;
- ADC, DAC, AC; etc.

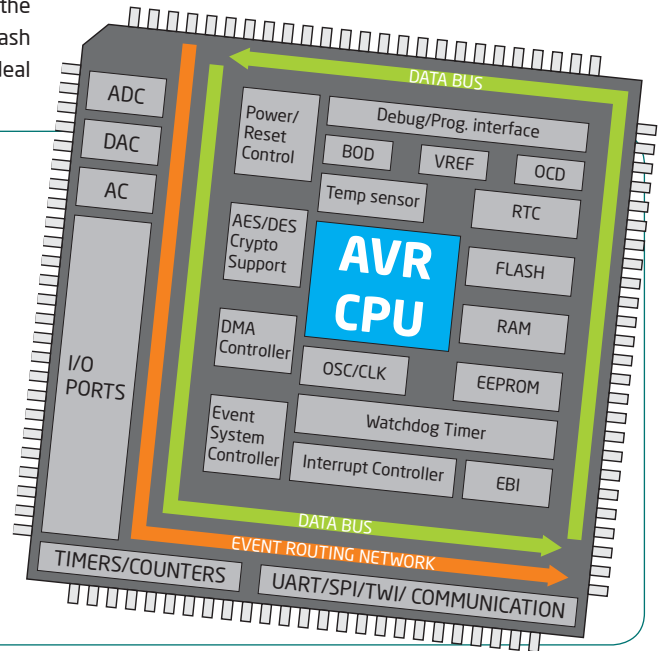

# 3. Programming the microcontroller

Figure 3-1:  
ATxmega128A1

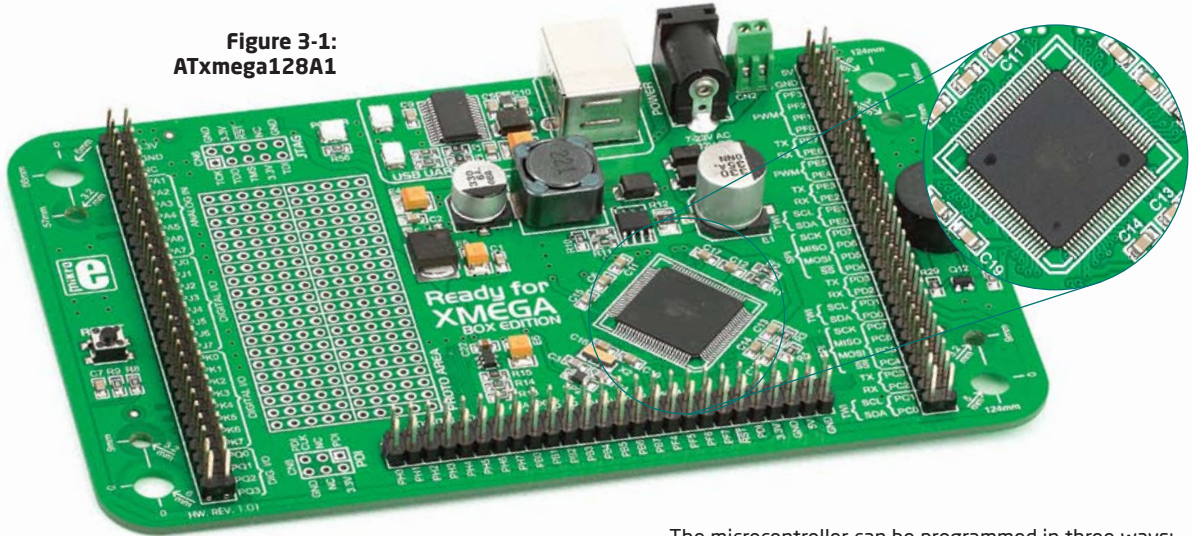

The microcontroller can be programmed in three ways:

- 01 Via USB-UART mikroBootloader
- 02 Using JTAG external programmer
- 03 Using PDI external programmer

# Programming with mikroBootloader

You can program the microcontroller with bootloader which is preprogrammed into the device by default. To transfer .hex file from a PC to MCU you need bootloader software (**mikroBootloader USB HID**) which can be downloaded from:



[http://www.mikroe.com/eng/downloads/get/1271/mikrobootloader\\_xmega\\_v101.zip](http://www.mikroe.com/eng/downloads/get/1271/mikrobootloader_xmega_v101.zip)

After software is downloaded, unrar it to a desired location, and start mikroBootloader USB HID software.

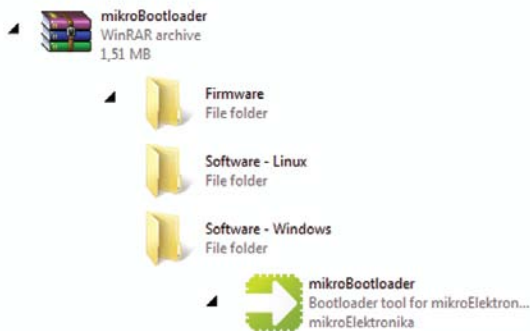

## note

*This version of mikroBootloader is specialized for ATxmega128A1 chip.*

## mikroBootloader software

**note** Before starting mikroBootloader software, connect Ready for XMEGA with a PC using USB cable provided with the package

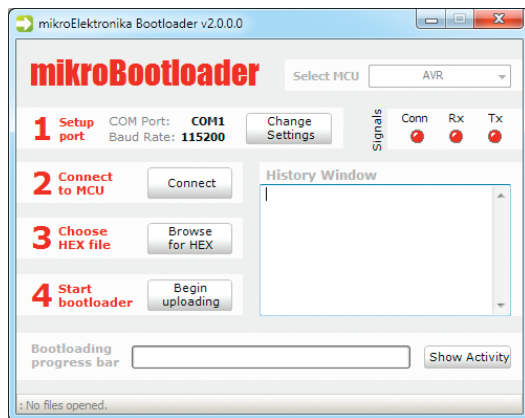

Figure 3-2: mikroBootloader window

01 When you start mikroBootloader software, a window shown on **Figure 3-2** should appear.

## Identifying device COM port

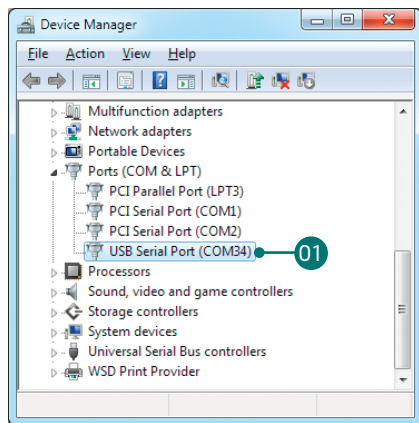

Figure 3-3: Identifying COM port

- 01 Open **Device Manager** window and expand **Ports section** to see which COM port is assigned to Ready for XMEGA board (in this case COM34)

## step 1 - Choosing COM port

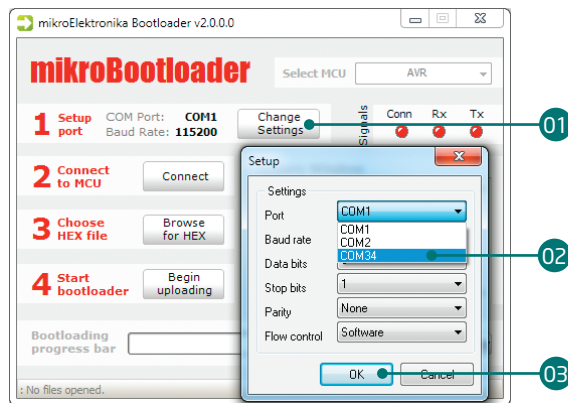

Figure 3-4: Choosing COM port

- 01 Click the **“Change Settings”** button.
- 02 From the drop down list, select appropriate COM **port** which is used for communication with a PC
- 03 Click **OK**.

## step 2 - Establishing Connection

**note:** Baud rate is set to 115200bps by default.

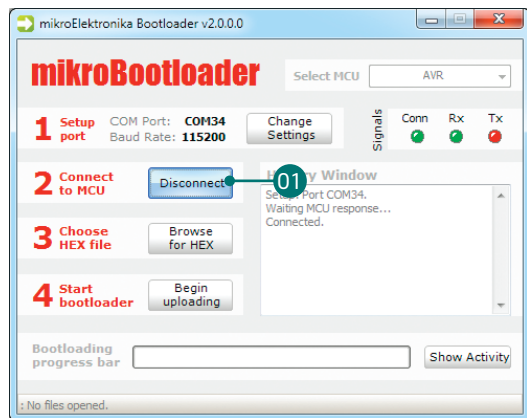

Figure 3-5: Connecting with mikroBootloader

- 01 Press **"Reset"** button on Ready for XMEGA board and click **"Connect"** button within 5s, otherwise existing microcontroller program will execute. If connected, caption on a button will be changed to **"Disconnect"**.

## step 3 - Browsing for .HEX file

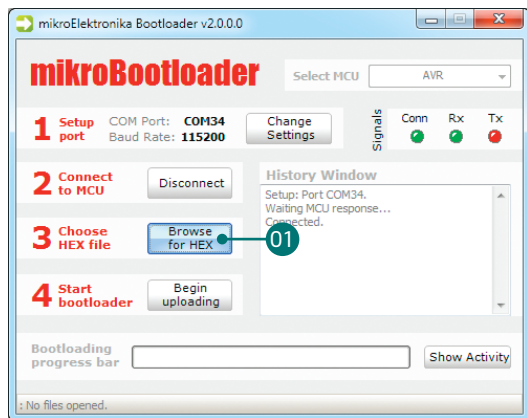

Figure 3-6: Browse for HEX

- 01 Click the **"Browse for HEX"** button and from a pop-up window (Figure 3.7) choose .HEX file which will be uploaded to MCU memory

## step 4 - Selecting .HEX file

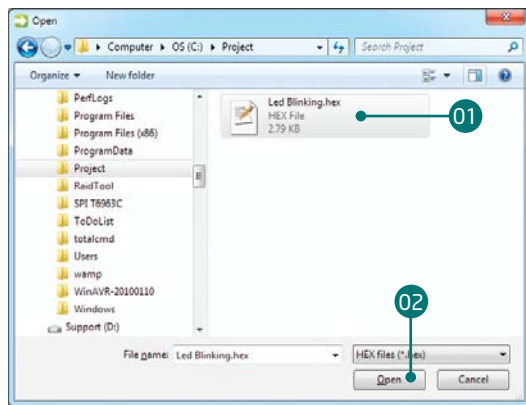

Figure 3-7: Locating and Selecting .hex file

- 01 Select .HEX file using open dialog window.
- 02 Click the **"Open"** button.

## step 5 - Uploading .HEX file

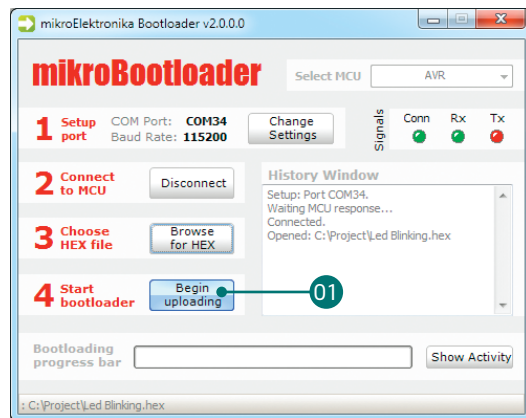

Figure 3-8: Begin uploading

- 01 To start .HEX file bootlodng click the **"Begin uploading"** button.



## step 6 - Progress bar

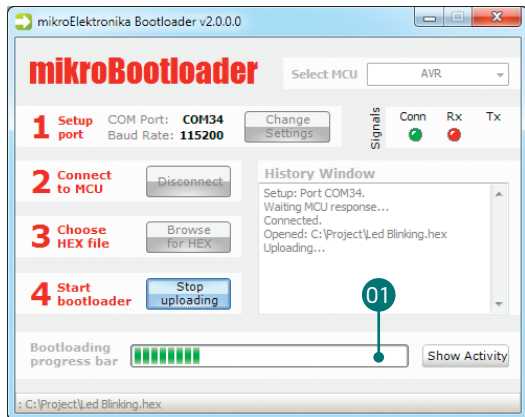

Figure 3-9: Progress bar

- 01 You can monitor .HEX file uploading via progress bar.

## step 7 - Finish upload

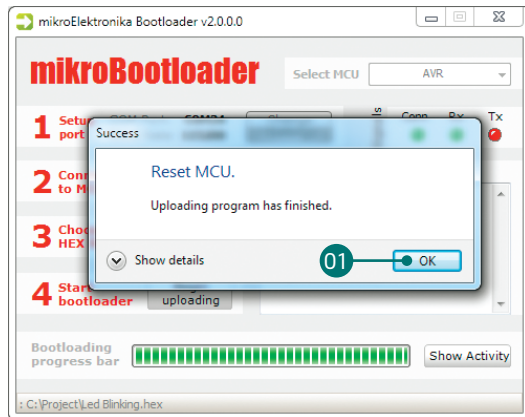

Figure 3-10: Restarting MCU

- 01 Click **"OK"** button after uploading is finished.
- 02 Press **"Reset"** button on Ready for XMEGA board and wait for 5 seconds. Your program will execute automatically.

# Programming with JTAG programmer

Figure 3-11:  
placing 10 pin header

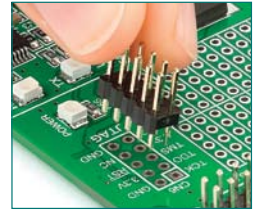
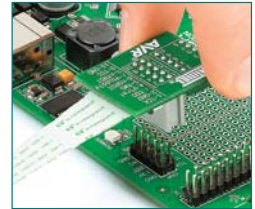

Figure 3-12:  
connecting JTAG  
programmer



Ready for XMEGA board contains **JTAG connector pads** so you can program the board and debug your code using external programmer/debugger. Before connecting the programmer you have to solder the provided **IDC10 2x5 male header** onto the board's JTAG connector pads. If bootloader program is accidentally erased, you can upload it again via AVR JTAG or PDI programmer. Ready for XMEGA Bootloader **Firmware.hex** can be found under Firmware folder (see page 12).

# Programming with PDI programmer

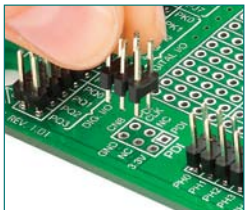
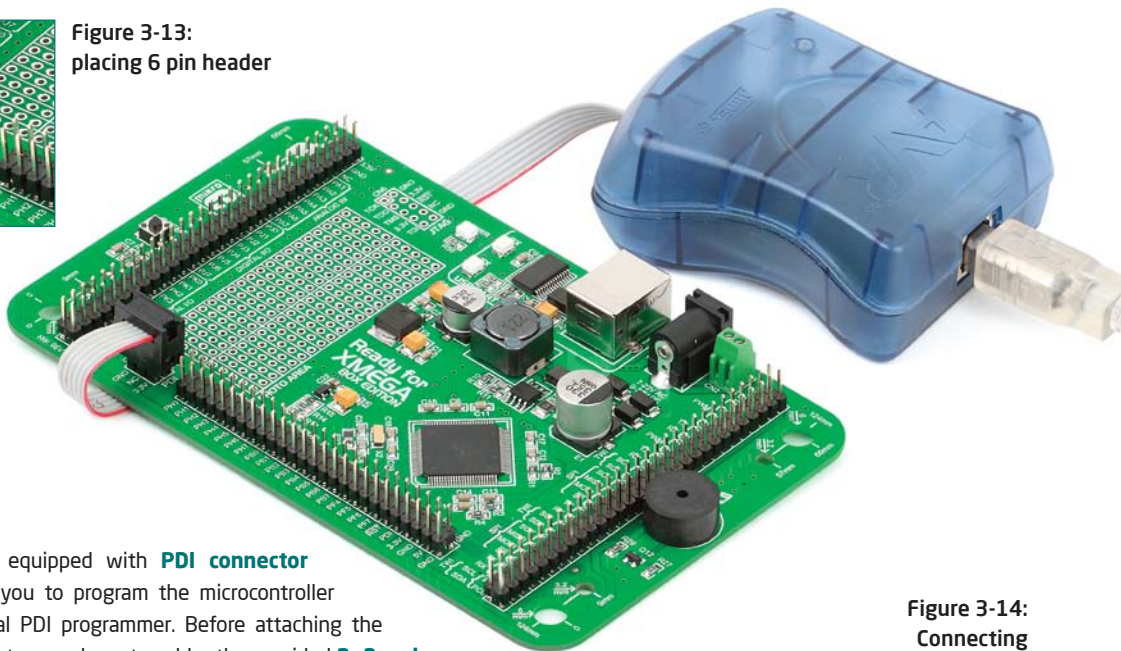

Figure 3-13:  
placing 6 pin header



The board is also equipped with **PDI connector pads**, which allow you to program the microcontroller using external serial PDI programmer. Before attaching the programming connector, you have to solder the provided **2x3 male header** to the board's PDI connector pads.

Figure 3-14:  
Connecting  
PDI programmer

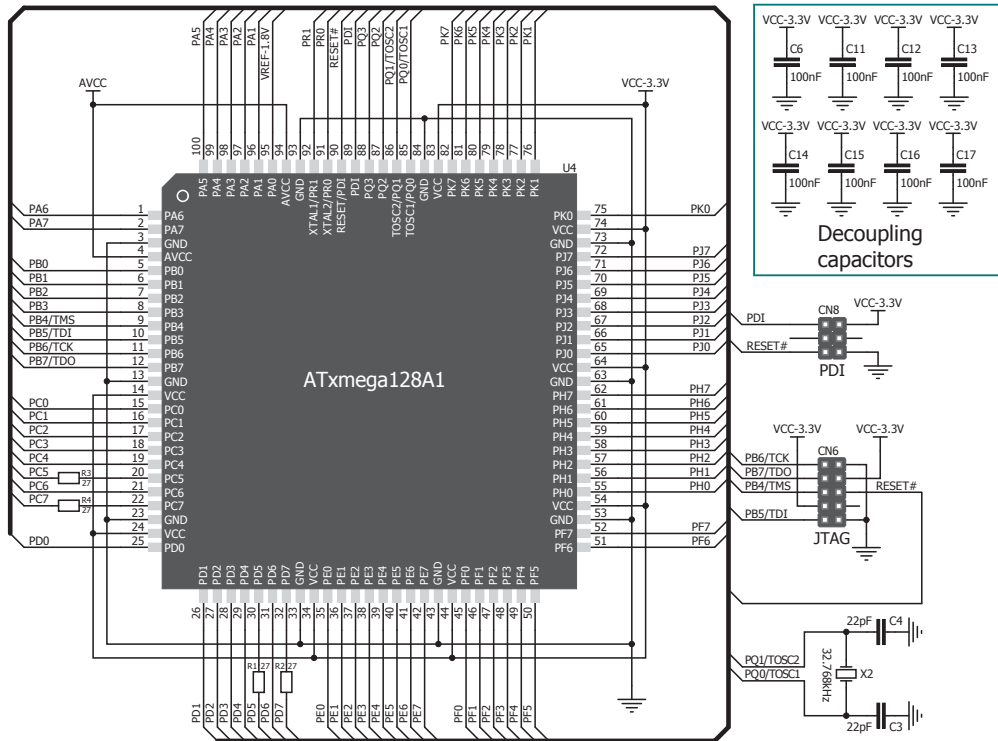

Figure 3-15: PDI & JTAG programmer connection schematics

# 4. USB-UART

Fast on-board **FTDI® chip** allows you to communicate with a PC or other UART devices using USB-UART connection. USB-B connector (**CN3**) is used for connecting the USB cable. RX (receive) and TX (transmit) LEDs will indicate communication status. Before connecting the board with the PC, make sure to have the appropriate **FTDI drivers** installed on your operating system. Drivers can be found at following URL:

<http://www.ftdichip.com/Drivers/VCP.htm>

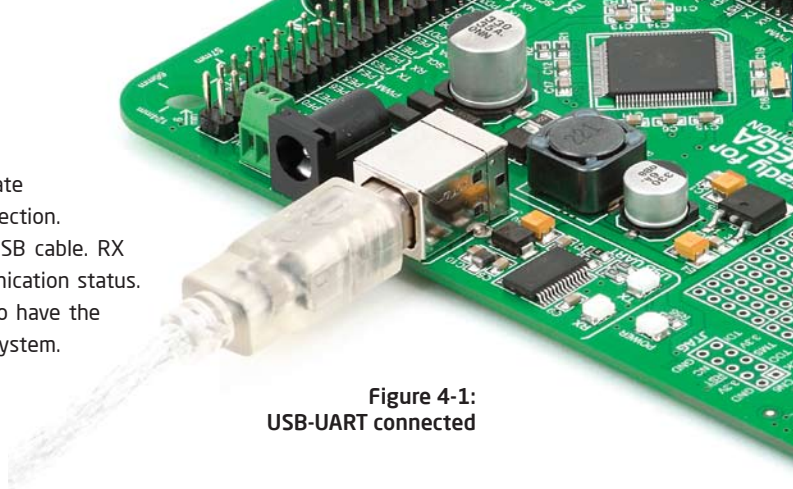

Figure 4-1:  
USB-UART connected

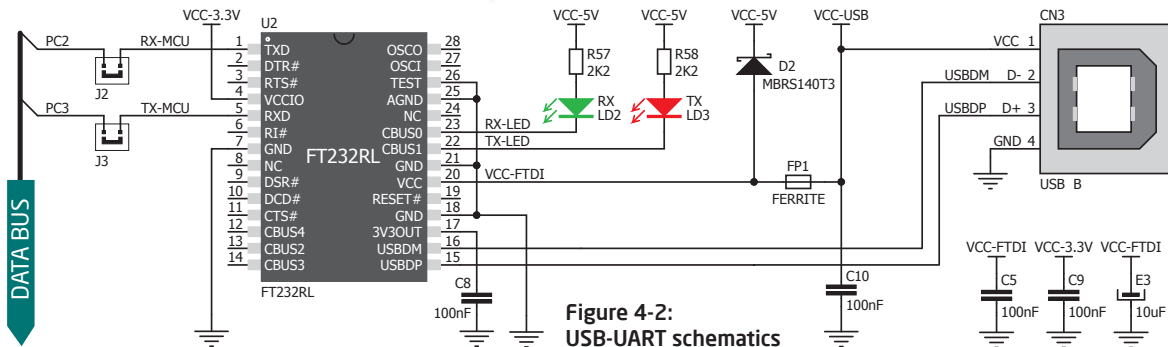
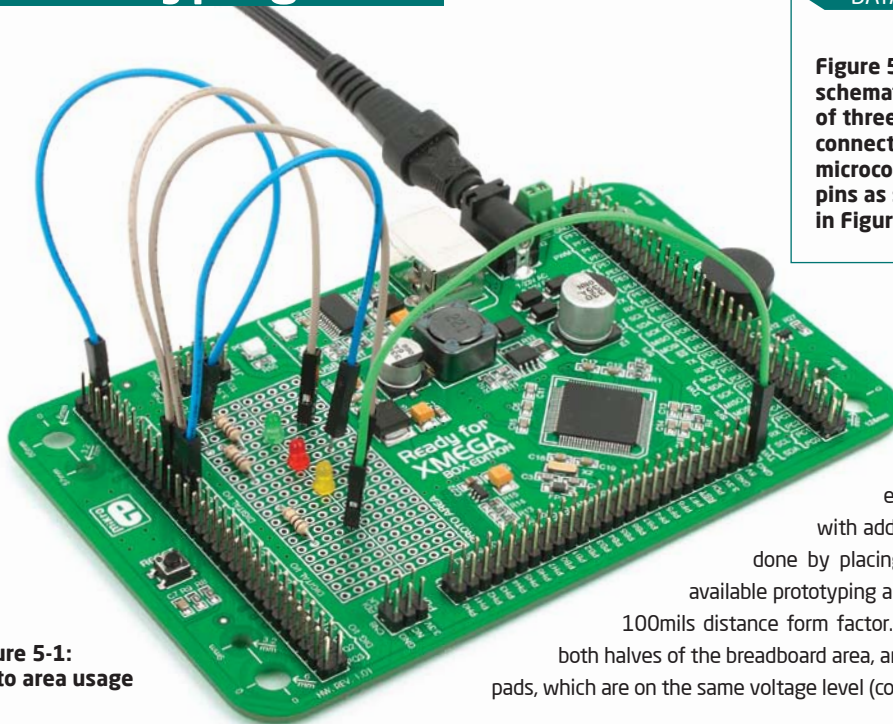
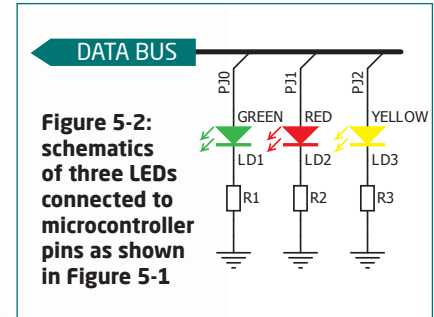

Figure 4-2:  
USB-UART schematics

## 5. Prototyping area



**Figure 5-1:**  
Proto area usage



**Proto area** allows you to expand your Ready for XMEGA board with additional functionalities. That can be done by placing your additional components on available prototyping area. Pads are arranged in standard 100mils distance form factor. There are 20 connected lines on both halves of the breadboard area, and each line consists of 5 soldering pads, which are on the same voltage level (connected to each other).



# 6. Pin headers

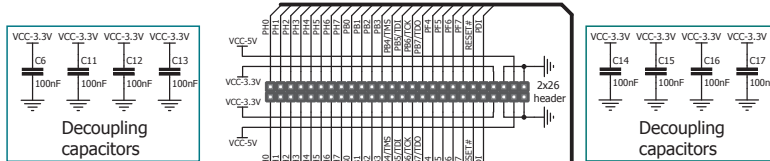

Figure 6-2: Pin headers

Each microcontroller pin is available for further connections through on-board connection headers. Each line is available in two header pins. Pins are grouped according to their functions, which makes development and connections much easier. Everything is printed on the silkscreen while developing. Before using the pins, you have to solder the provided **2x30** and **2x26 male headers** onto the board's pads.

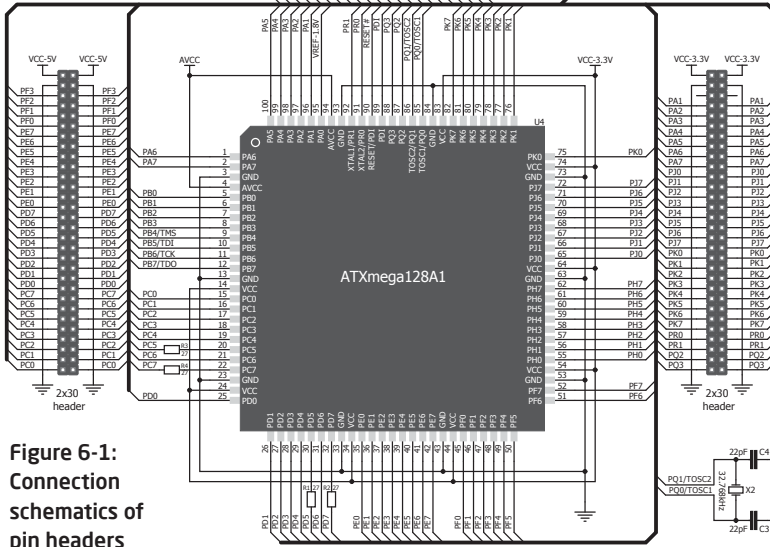
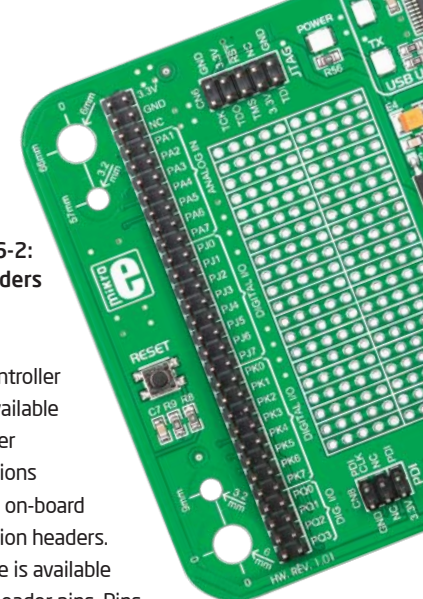
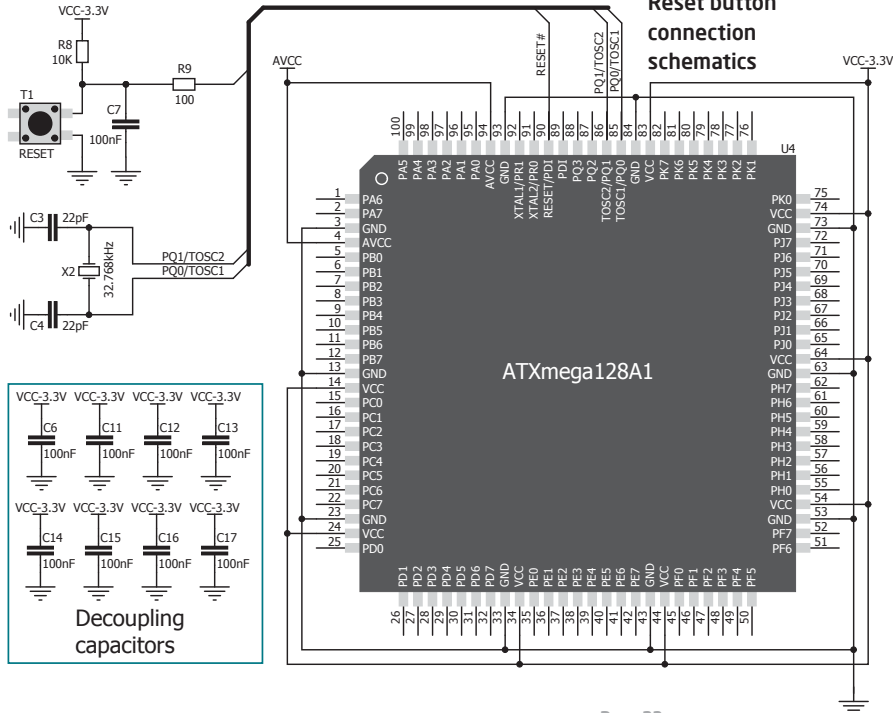

Figure 6-1: Connection schematics of pin headers





# 7. Reset button



Ready for XMEGA board has a specialized reset circuit with high-quality reset button, which can be used to reset the program execution of the microcontroller. If you want to reset the circuit, press on-board RESET button. It will generate low voltage level on microcontroller reset pin (input). In addition, a reset can be externally provided through **RST pin** on 2x26 header (**Figure 6-1**).

# 8. Piezo buzzer

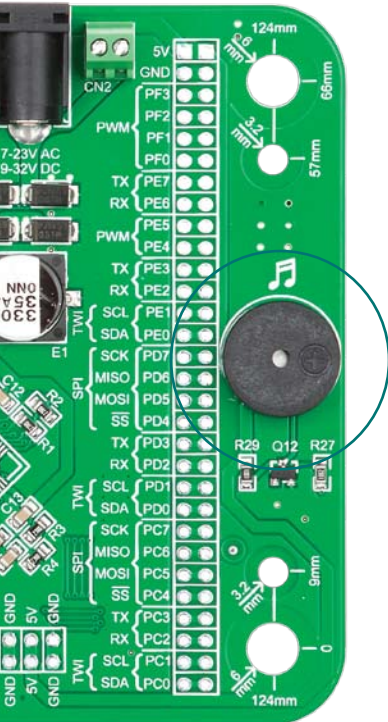

On-board piezo buzzer is a very useful module which can be used in debugging your code, or to have audio signalization feature when board is integrated as a final product. Piezo buzzer's resonant frequency is 3.8kHz. In addition, other frequencies in the range between 20Hz and 20.000Hz can be used, but the best performance is provided by frequencies ranging between 2kHz and 4kHz.

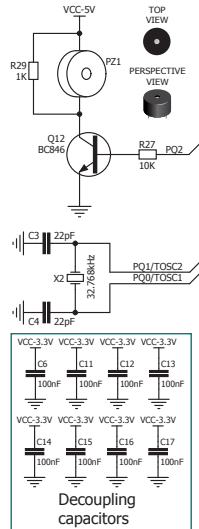

**Figure 8-1:**  
Piezo buzzer

**Figure 8-2:**  
Piezo buzzer  
connection  
schematics

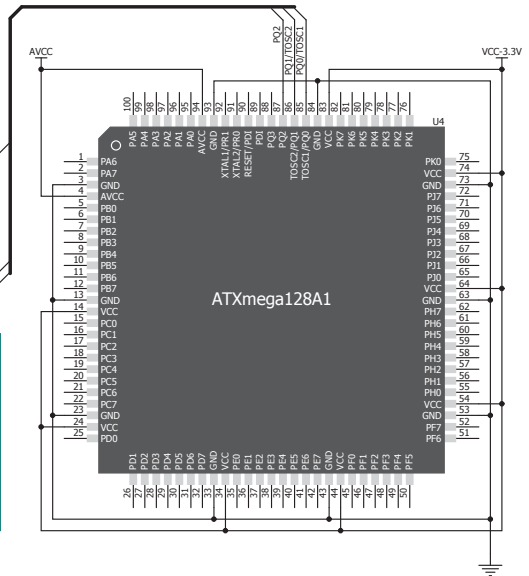

## 9. Integrating with the casing



**Figure 9-1:**  
Place the board into the bottom part of the casing. Make sure to align the connectors with the square openings



**Figure 9-2:**  
Wind screws into inner screw holes to mount the board to the bottom casing plastic



**Figure 9-2:**  
Place cover casing plastic and wind screws into outer screw holes for connecting it with bottom plastics

Ready for XMEGA can easily be integrated into the specialized white plastic casing. This feature is very convenient for turning the board into a final product. The white plastic casing contains inner and outer screw holes. Inner are used for attaching the board to the casing and outer are used for connecting the top part of the casing, and enclosing the board. Casing comes with holes for USB and power adapter connector, but you can customize it by drilling and cutting holes in specific areas, depending on the target application.

# 10. Dimensions

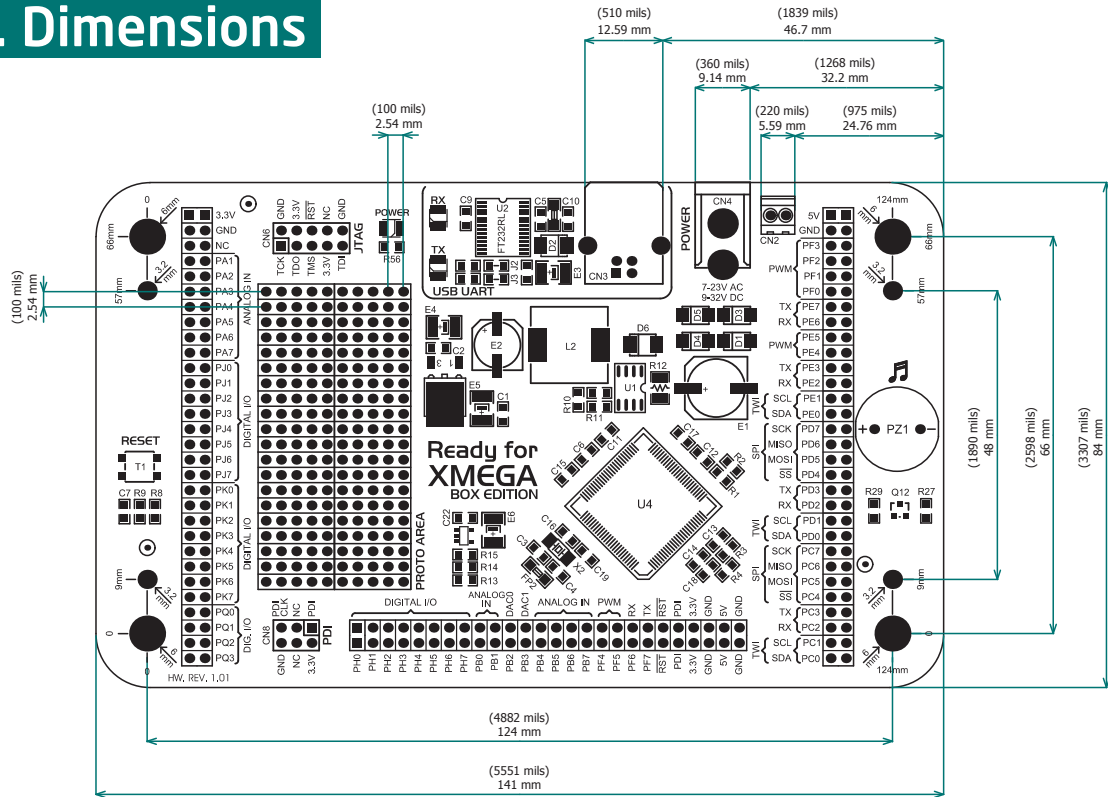

## DISCLAIMER

All the products owned by MikroElektronika are protected by copyright law and international copyright treaty. Therefore, this manual is to be treated as any other copyright material. No part of this manual, including product and software described herein, may be reproduced, stored in a retrieval system, translated or transmitted in any form or by any means, without the prior written permission of MikroElektronika. The manual PDF edition can be printed for private or local use, but not for distribution. Any modification of this manual is prohibited.

MikroElektronika provides this manual 'as is' without warranty of any kind, either expressed or implied, including, but not limited to, the implied warranties or conditions of merchantability or fitness for a particular purpose.

MikroElektronika shall assume no responsibility or liability for any errors, omissions and inaccuracies that may appear in this manual. In no event shall MikroElektronika, its directors, officers, employees or distributors be liable for any indirect, specific, incidental or consequential damages (including damages for loss of business profits and business information, business interruption or any other pecuniary loss) arising out of the use of this manual or product, even if MikroElektronika has been advised of the possibility of such damages. MikroElektronika reserves the right to change information contained in this manual at any time without prior notice, if necessary.

## HIGH RISK ACTIVITIES

The products of MikroElektronika are not fault - tolerant nor designed, manufactured or intended for use or resale as on - line control equipment in hazardous environments requiring fail - safe performance, such as in the operation of nuclear facilities, aircraft navigation or communication systems, air traffic control, direct life support machines or weapons systems in which the failure of Software could lead directly to death, personal injury or severe physical or environmental damage ('High Risk Activities'). MikroElektronika and its suppliers specifically disclaim any expressed or implied warranty of fitness for High Risk Activities.

## TRADEMARKS

The MikroElektronika name and logo, the MikroElektronika logo, mikroC™, mikroBasic™, mikroPascal™, AVRProg™, Ready for XMEGA™, EasyAVR™, EasyAVR PRO™, Click Boards™ and mikromedia™ are trademarks of MikroElektronika. All other trademarks mentioned herein are property of their respective companies.

All other product and corporate names appearing in this manual may or may not be registered trademarks or copyrights of their respective companies, and are only used for identification or explanation and to the owners' benefit, with no intent to infringe.



If you want to learn more about our products, please visit our website at [www.mikroe.com](http://www.mikroe.com)

If you are experiencing some problems with any of our products or just need additional information, please place your ticket at [www.mikroe.com/esupport](http://www.mikroe.com/esupport)

If you have any questions, comments or business proposals,  
do not hesitate to contact us at [office@mikroe.com](mailto:office@mikroe.com)

Ready for XMEGA Manual  
ver. 1.00



0 100000 019061