

ATLANTIC VERSION TERMINATOR INTERFACE ADAPTER	PART NUMBER	REVISION	DESCRIPTION	FEED TYPE	APPLICATOR STYLE CONVERSION CHART						
					CONVERT TO	PART NUMBERS REQUIRED					
	2266410-1	A	FINE CRIMP HEIGHT ADJUST	MECHANICAL	PNEUMATIC FEED	2119950-1	1338685-1	5-18022-5	2119641-1	2119799-1	2063440-1
	2266410-2	A	FINE CRIMP HEIGHT ADJUST	PNEUMATIC	SERVO LATCH PLATE	2119951-1	-	8-2266410-5	1901094-3	-	2168400-6 (QUANTITY 2)
					SMART APPLICATOR	2161326-1	-	8-2266410-4	-	-	
					MECHANICAL FEED	2119949-1	1338685-1	5-18022-5	2119653-1	-	-
	2266410-5	A	FINE CRIMP HEIGHT ADJUST	SERVO LATCH PLATE	SERVO LATCH PLATE	2119951-1	-	8-2266410-5	1901094-3	-	2168400-6 (QUANTITY 2)
					SMART APPLICATOR	2161326-1	-	8-2266410-4	-	-	
					MECHANICAL FEED	2119949-1	1338685-1	5-18022-5	2119653-1	-	-
2266410-6	A	NON-CRIMP HEIGHT ADJUST	SERVO LATCH PLATE	PNEUMATIC FEED	2119950-1	1338685-1	5-18022-5	2119641-1	2119799-1	2063440-1	
				-	-	-	-	-	-	-	
2266410-7	A	FINE CRIMP HEIGHT ADJUST	NONE	-	-	-	-	-	-	-	
7-2266410-7	A	CRIMP TOOLING KIT	-	-	-	-	-	-	-	-	

APPLICATOR DATA		
CRIMP	SIZE	TYPE
WIRE	2.03 mm [.080]	F
INSUL	4.57 mm [.180]	O

APPLICATOR INSTRUCTIONS 408-10389

TERMINAL DATA: HULANE TERMINAL	TE CRIMP SPECIFICATION		
TERMINAL NAME: TERMINAL			
WIRE STRIP LENGTH 4.88-5.64 mm [.192-.222 IN]	INSULATION DIAMETER RANGE Ø 1.30mm MAX [.051 IN] MAX		
TERMINAL APPLICATION SPECIFICATION NONE			
TERMINALS APPLIED			
TE TERMINAL	HULANE TERMINAL	TE SEAL	FANGYUAN SEAL
2113526-1	(6)619037PS7	2113500-1	7165-33541A
		2113527-1	85901100215

WIRE SIZE	CRIMP HEIGHT mm [INCH]	CRIMP HEIGHT REFERENCE SETTING
1.25mm2	1.32+/-0.05 [.052+/-0.002]	5.1
1.00mm2	1.22+/-0.05 [.048+/-0.002]	6.2
0.85mm2	1.15+/-0.05 [.045+/-0.002]	7.1

- 1. RECOMMENDED SPARE PARTS
- 2. GREASE BEARING SURFACES LIGHTLY
- 3. LUBRICATE DAILY PER THE APPLICATOR INSTRUCTION SHEET SUPPLIED WITH THE APPLICATOR.
- 4. APPLICATOR SPECIFIC DATA TO BE ENTERED INTO BLANK MEMORY CHIP AT ASSEMBLY. SEE BELOW FOR PART NUMBER:
MECHANICAL FEED WITH "SMART APPLICATOR" CONVERSION: 8-2266410-4
PNEUMATIC FEED WITH "SMART APPLICATOR" CONVERSION: 8-2266410-4
SERVO FEED WITH "FINE CRIMP HEIGHT ADJUST": 8-2266410-5
SERVO FEED WITH "NON-CRIMP HEIGHT ADJUST": 8-2266410-6
- 5. ADJUSTMENT OF THE STRIPPER MAY BE REQUIRED WHEN MOVING THE APPLICATOR BETWEEN BENCH AND LEADMAKER APPLICATIONS.
- 6. APPLY PART NUMBER 1-23419-5 LOCTITE TO THREADS OF ITEM 62. APPLY PART NUMBER 2-23419-6 LOCTITE TO THREADS OF ITEM 242. FOR -6 ONLY APPLY PART NUMBER 1-23419-5 LOCTITE TO THREADS OF ITEM 37.
- 7. GREASE THREADS, GROOVE AND O-RING ON ITEMS 35 & 252.
- 8. MAGNET, ITEM 166 MUST BE ORIENTED CORRECTLY IN ORDER TO PROPERLY ACTUATE THE COUNTER.
- 9. CRIMP HEIGHT REFERENCE SETTING WAS THE SETTING USED WHEN THE APPLICATOR WAS QUALIFIED AT THE FACTORY. ADJUSTMENT MAY BE NECESSARY WHEN RUNNING APPLICATOR IN THE FIELD.
- 10. SPARE FEED CAM STORAGE LOCATION REFER TO INSTRUCTION SHEET FOR ADDITIONAL INFORMATION.
- 11. TO CONVERT THE APPLICATOR TO A NON-CARRIER CUTTING STYLE, REMOVE ITEM 13 AND ATTACH TO THE LOCATION ON THE BACK SIDE OF THE HOUSING. REFER TO INSTRUCTION SHEET FOR ADDITIONAL INFORMATION.
- 12. WHEN ASSEMBLING A NON CRIMP HEIGHT ADJUST APPLICATOR (-6) USE SHIMS FROM ITEM 260 TO ACHIEVE A NOMINAL SHIM HEIGHT OF 4.48. THIS APPLICATOR APPLIES TERMINAL WITH A SEAL.
- 13. APPLY TORO-SEAL IN ALLEN SOCKET TO FILL HOLE AFTER FLAT HD HAS BEEN ADJUSTED TO CORRECT HEIGHT AT QUALIFICATION. APPLY #1-23419-5 LOC-TITE TO THREADS.

***WARNING**
ON INSTALLATION, SET WIRE DISC, ITEM 40 TO LARGEST WIRE SIZE SETTING. USE OF SETTINGS BELOW MINIMUM REQUIRED CRIMP HEIGHT SETTING WILL CAUSE DAMAGE TO CRIMP TOOLING.

ATLANTIC VERSION
Shown on sheets 1 of 4 & 2 of 4
(Pacific version shown on sheets 3 of 4 & 4 of 4)

SET UP GAUGE	LOC	DIST	REVISIONS			
2119599-1	A	66	P	DATE	OWN	APVD
			1	DEVELOPMENT	09JUL2014	JH UG
			A	RELEASED	19AUG2014	JH TE

P	LTN	DESCRIPTION	DATE	OWN	APVD
-	-	1 - - - -	2119957-2	APPLICATOR SHIM PACK	260
-	1	- 1 1 1	8-21084-0	O-RING, .676 ID, .070 DIA. MAT.	252
-	-	- - 1 -	2119640-1	PUSH ROD, AIR FEED	250
-	-	- - 1 -	2079988-1	BUSHING, LCH5-12, MISUMI	249
-	-	- - 1 -	2119641-1	FEED CAM, AIR FEED	248
-	1	- 1 1 1	2119798-1	DETENT PIN	247
-	1	- 1 1 1	1-22279-3	SPRING, COMPRESSION	246
-	-	1 - - -	2119758-1	RAM, AMP STYLE, SIDE FEED, NON-ADJ.	245
-	1	1 1 1 1	2119082-3	CAM, SNAIL, INSULATION ADJUSTMENT	244
-	1	1 1 1 1	2079764-1	WASHER, WAVE SPRING, CREST-TO-CREST	243
-	1	1 1 1 1	2119083-1	RETAINER, INSULATION DIAL	242
-	1	1 1 1 1	7-18023-7	SCR, SKT HD CAP M3 X 4.0	241
-	-	2 2 - -	2168400-6	SHCS, LOW HEAD, RoHS, M5 X 16	240
-	-	- - - 1	2119580-1	MECHANICAL FEED ASSEMBLY	239
-	-	- - 1 -	2063440-1	AIR FEED MODULE	238
-	-	1 1 - -	2119740-2	TAG, IDENTIFICATION	213
-	-	1 1 - -	1901094-3	SPACER, FEEDER	198
-	-	- - 2 -	21045-3	RING, RETAIN, EXTERN, 3/16 CRESCENT	172
-	1	1 1 1 1	994969-1	MAGNET, RARE EARTH HIGH ENERGY	166
-	REF	REF REF REF REF	994970-2	COUNTER, MAGNETIC	164
-	-	- - 1 -	240638-1	SPRING, FEED FINGER	163
-	-	- - 1 -	3-23627-7	PIN, RETAIN, GRVD, 3/16 X .854	137
-	-	- - 1 -	2119799-1	HOLDER, FEED FINGER, AF	136
-	-	REF REF - -	SEE NOTE 4	MEMORY CHIP, PROGRAMMED	135
-	-	1 1 - -	1633743-1	SERVO FEED LATCH ASM	133
-	-	REF REF - -	2119944-1	FEED FINGER ASSEMBLY, SF	117
-	1	1 1 1 1	455888-5	SPACER, CRIMPER	82
-	1	1 1 1 1	2119956-1	DOCUMENTATION PACKAGE	71
-	1	- - 1 1	2119740-1	TAG, IDENTIFICATION	67
-	2	2 2 2 2	2168078-1	SCREW, DRIVE, RH, RoHS, 2 x .188	66
-	1	- 1 1 1	2119793-1	LIMITER, ADJUSTMENT BOLT	63
-	3	- 3 3 3	992763-5	SCR, SET, SOC, CONE POINT, M3 x 4.0	62
-	1	1 1 1 1	2079383-4	SCR, BHSC, RoHS (M4 X 8)	60
-	-	- - 1 1	5-18022-5	SCR, HEX HD CAP, M4 X 6.0	59
-	1	1 1 1 1	985575-3	SCR, FLT SKT HD CAP M3 X 10.0	57
-	-	- - 1 1	1338685-1	PAWL, FEED	56
-	4	4 4 4 4	2168400-1	SHCS, LOW HEAD, RoHS, M4 X 12	54
-	2	2 2 2 2	1-2168083-4	SCR, SKT HD CAP, RoHS, M4 X 5	53
-	-	- - 1 2	18023-9	SCR, SKT HD CAP M4 X 6.0	49
-	-	- - - 1	2119652-1	FEED CAM, PRE FEED	48
-	-	- - - 1	2119653-1	FEED CAM, POST FEED	47
-	1	1 1 1 1	2119656-9	APPLICATOR BASIC ASSEMBLY, SF	46
-	1	- 1 1 1	2119370-1	RAM, AMP STYLE, SIDE FEED	44
-	1	1 1 1 1	2079383-7	SCR, BHSC, RoHS (M8 X 25)	41
-	1	- 1 1 1	2119645-1	DISC, NUMBERED FA WIRE ADJUSTMENT	40
-	1	- 1 1 1	2119957-1	APPLICATOR SHIM PACK	39
-	1	1 1 1 1	2119644-1	RAM WASHER, PRECISION	38
-	1	1 1 1 1	2119085-1	FA HEAD, ATLANTIC STYLE	37
-	1	- 1 1 1	2119092-1	BOLT, ADJUSTMENT	35
-	1	1 1 1 1	1752356-1	SUPPORT, TERMINAL	34
-	2	2 2 2 2	2079383-5	SCR, BHSC, RoHS (M4 X 20)	33
-	1	1 1 1 1	2161328-1	HEX HEAD, FLANGED, M5 x 8mm LONG	32
-	1	1 1 1 1	1320908-3	SPACER, STRIP GUIDE	30
-	1	1 1 1 1	2119959-1	ASSEMBLY, STRIP GUIDE	29
-	1	1 1 1 1	455888-3	SPACER, CRIMPER	28
-	1	1 1 1 1	1320928-2	STRIP GUIDE	24
-	1	1 1 1 1	2168083-2	SCR, SKT HD CAP, RoHS, M4 X 8.0	21
-	4	4 4 4 4	1-18028-2	WASHER, FLAT, REG M4	20
-	1	1 1 1 1	2119533-1	STRIPPER, SIDE FEED	19
-	1	1 1 1 1	5-690518-2	HOLD DOWN, TERMINAL	18
-	1	1 1 1 1	2119806-1	INSERT, SHEAR	13
-	1	1 1 1 1	3-22280-3	SPRING, COMPRESSION	12
-	1	1 1 1 1	1-356885-4	STOP, SHEAR	11
-	1	1 1 1 1	2119805-1	SHEAR HOLDER, FRONT	10
-	1	1 1 1 1	318707-1	FLOATING SHEAR, FRONT	9
1	1	1 1 1 1	3-1633920-1	ANVIL, COMBINATION	8
-	-	- - - -	-	-	7
-	-	- - - -	-	-	6
-	1	1 1 1 1	2119781-1	DEPRESSOR, SHEAR	5
-	1	1 1 1 1	2-238011-1	BLOCK, CRIMPER SPACER	4
1	1	1 1 1 1	6-2119784-0	CRIMPER, INSULATION O PREMIUM	3
-	1	1 1 1 1	1-455888-0	SPACER, CRIMPER	2
1	1	1 1 1 1	456405-8	CRIMPER, WIRE PREMIUM	1
-77	-7	-6 -5 -2 -1	PART NO	DESCRIPTION	ITEM NO

DIMENSIONS: mm		TOLERANCES UNLESS OTHERWISE SPECIFIED:		OWN J. HOU 10JULY2014		TE Connectivity	Harrisburg, PA 17105-3608
		0 PLC ±.05 1 PLC ±.05 2 PLC ±.05 3 PLC ±.05 4 PLC ±.05 ANGLES ±.0001		CHK Y. YIN 10JULY2014		NAME	
MATERIAL	FINISH	APPLICATOR SPEC		APVD H. GUO 10JULY2014	PRODUCT SPEC	Customer Accessible Production Drawing	
		APPLICATION SPEC		SIZE CASE CODE DRAWING NO		RESTRICTED TO	
		WEIGHT		A1 00779 C=2266410		SCALE SHEET 1 OF 4 REV A	

LOC	DIST	REV	DATE	BY	APPV
A	66				

FEED TYPE MECHANICAL

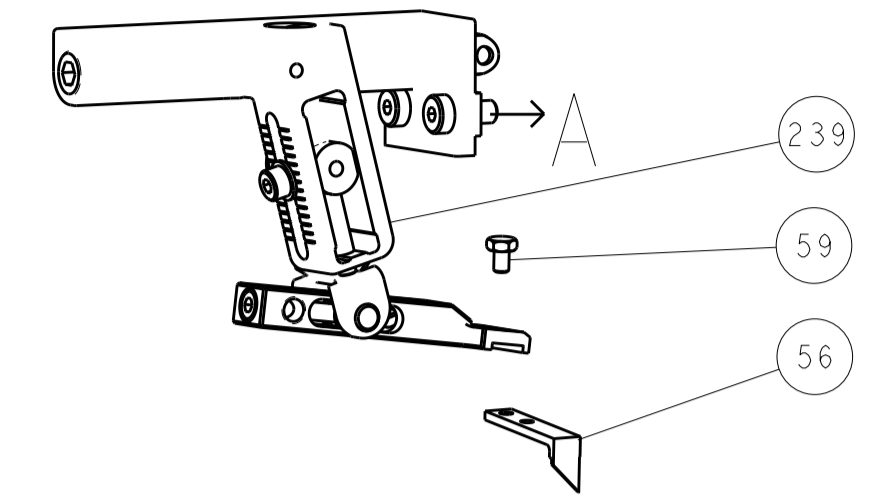

PNEUMATIC

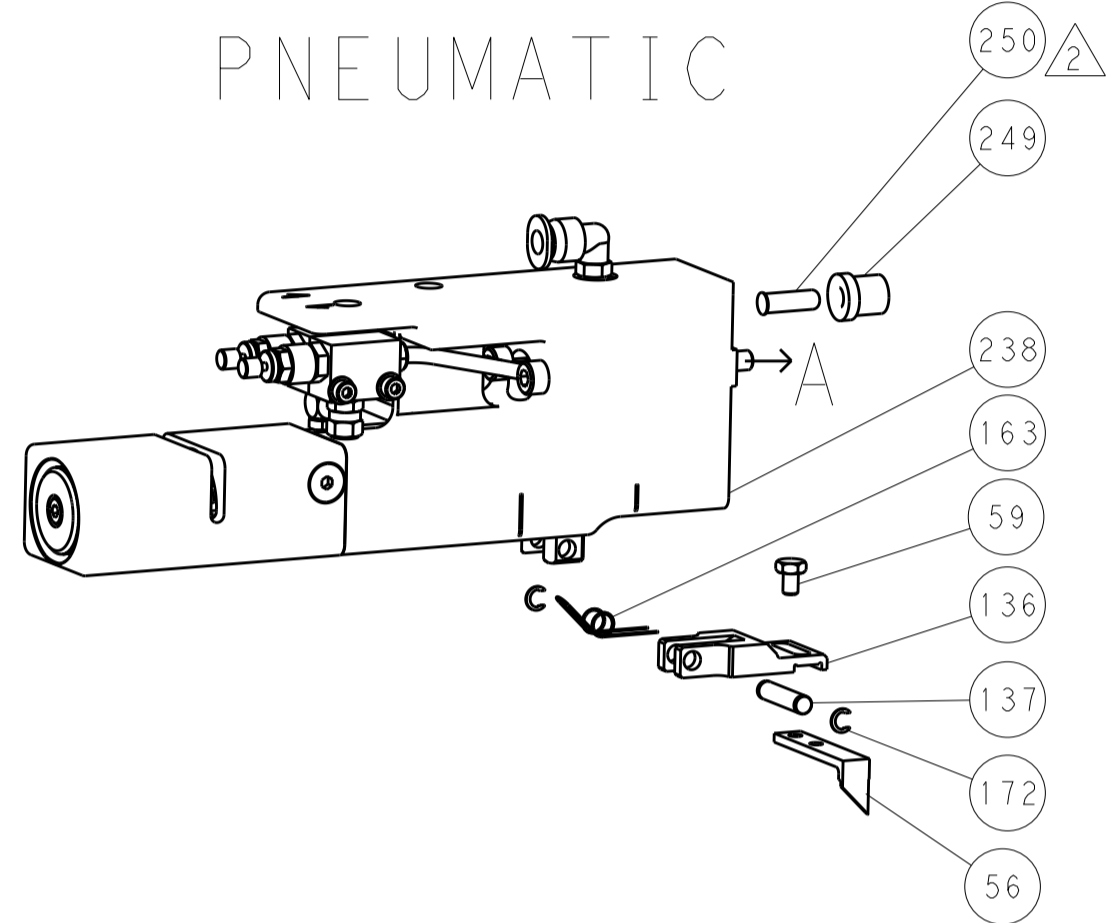

SERVO LATCH PLATE

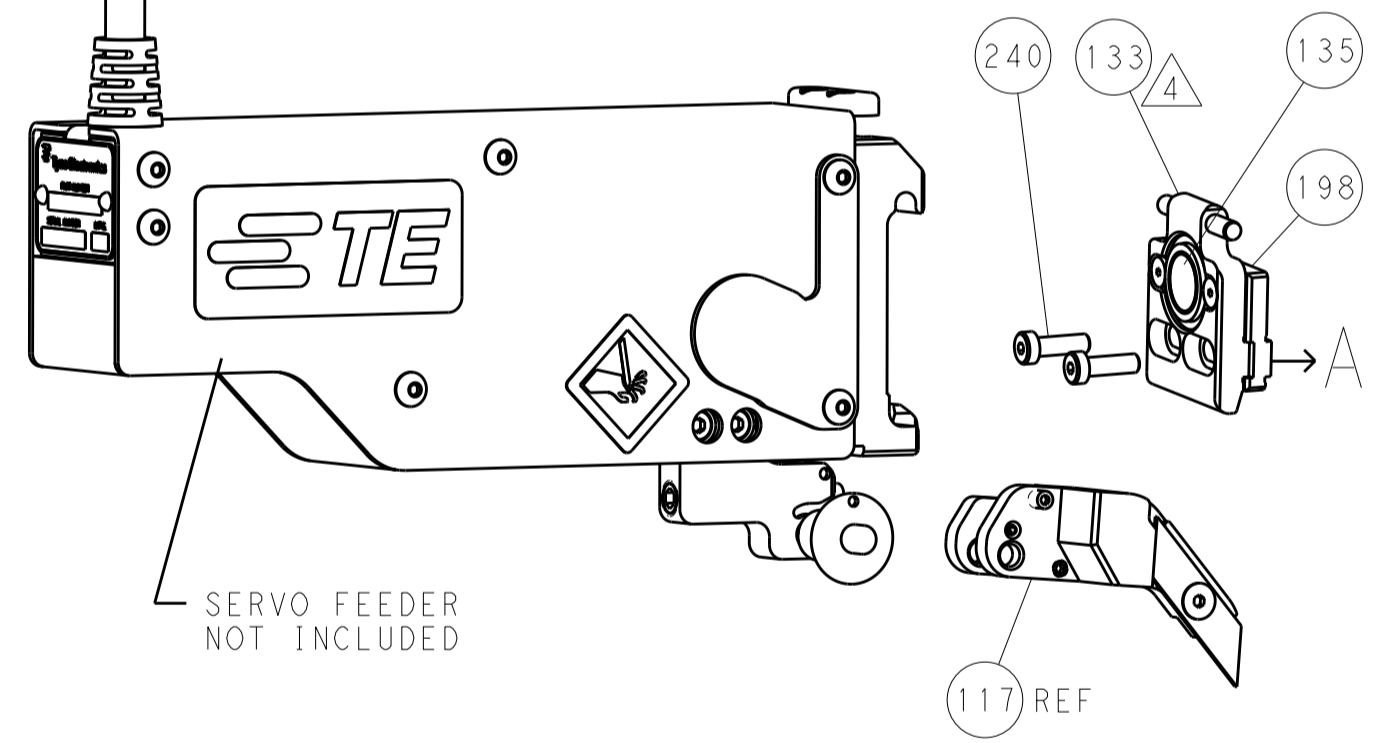

CAM POSITIONS

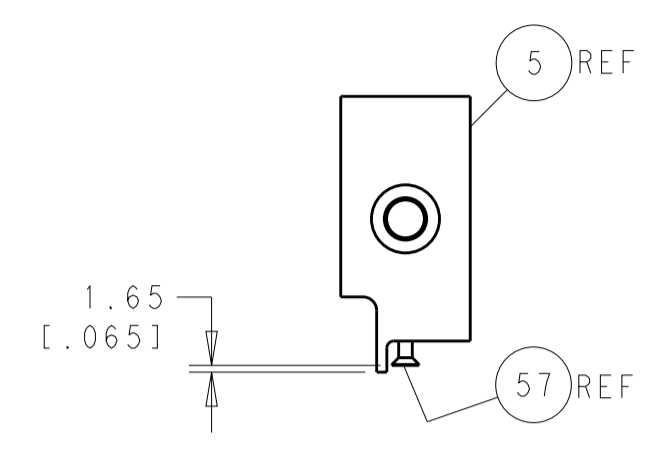
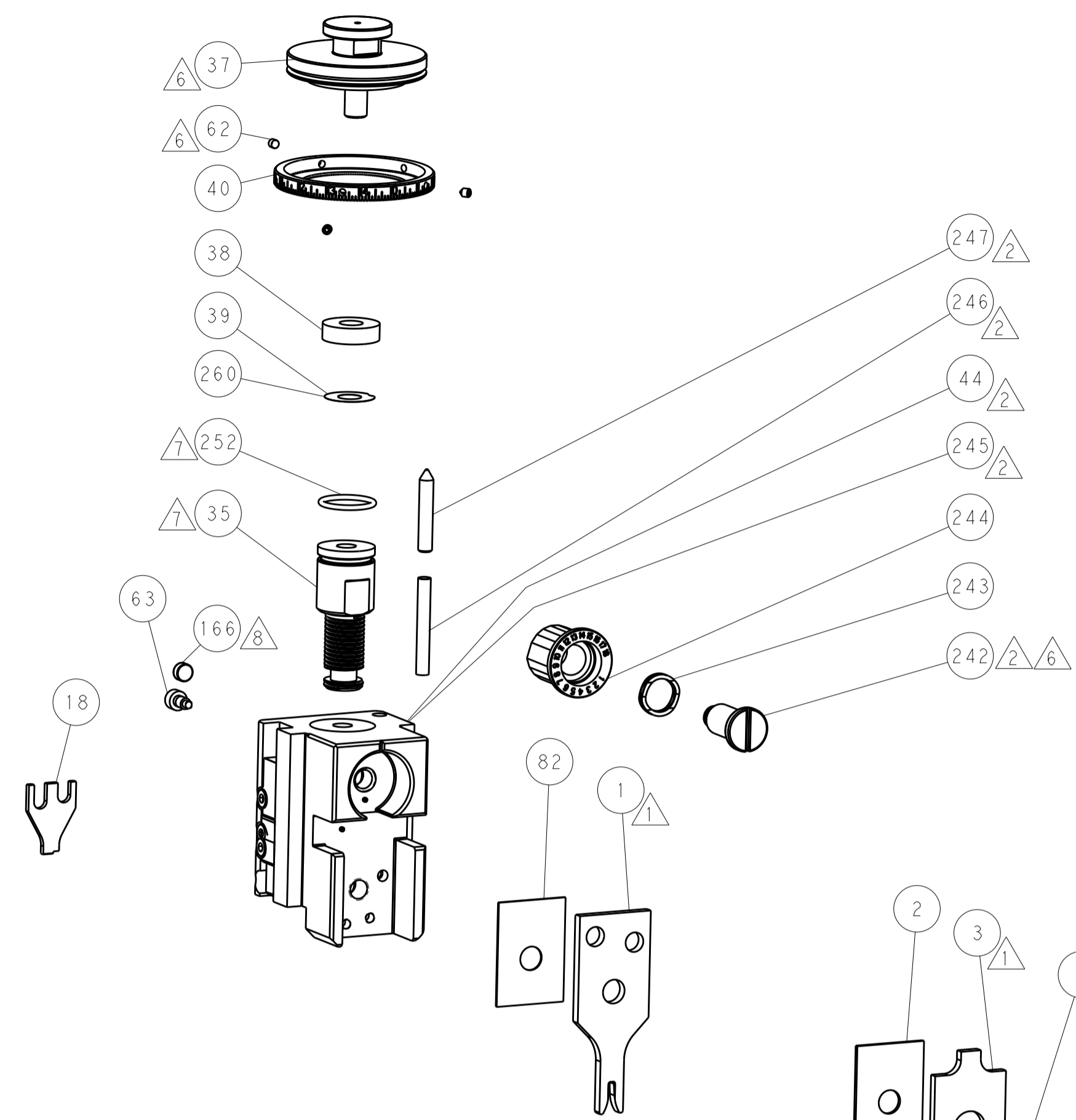

SHEAR DEPRESSOR DETAIL

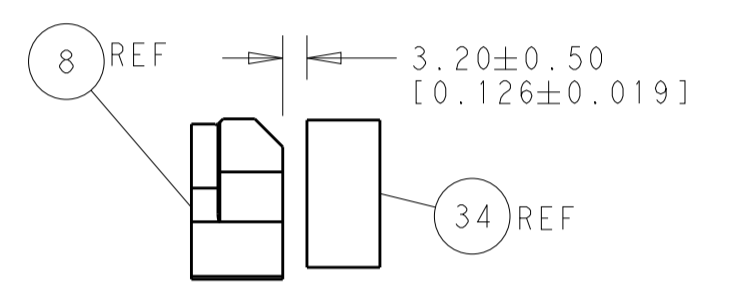

TERMINAL SUPPORT LOCATION

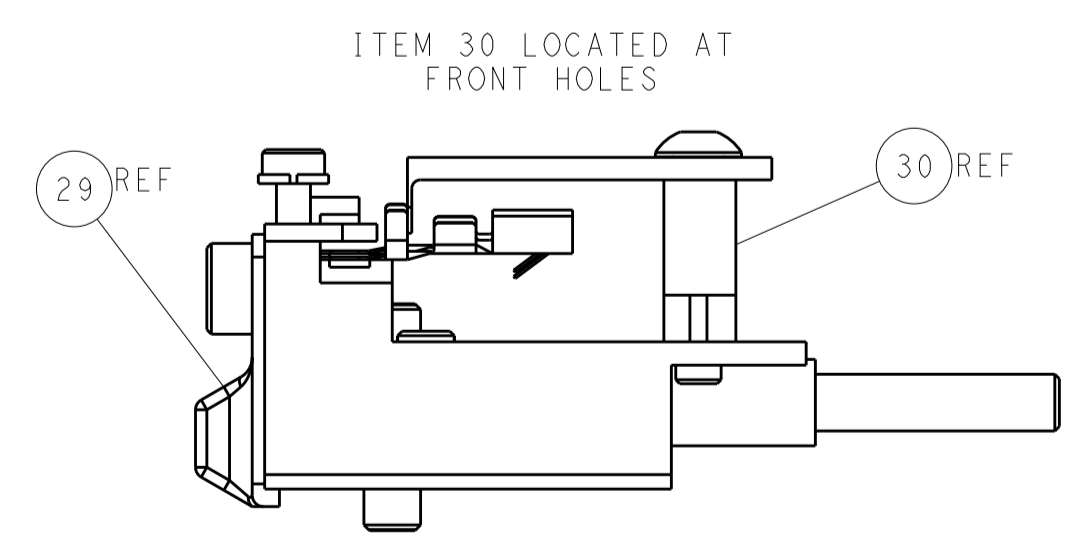
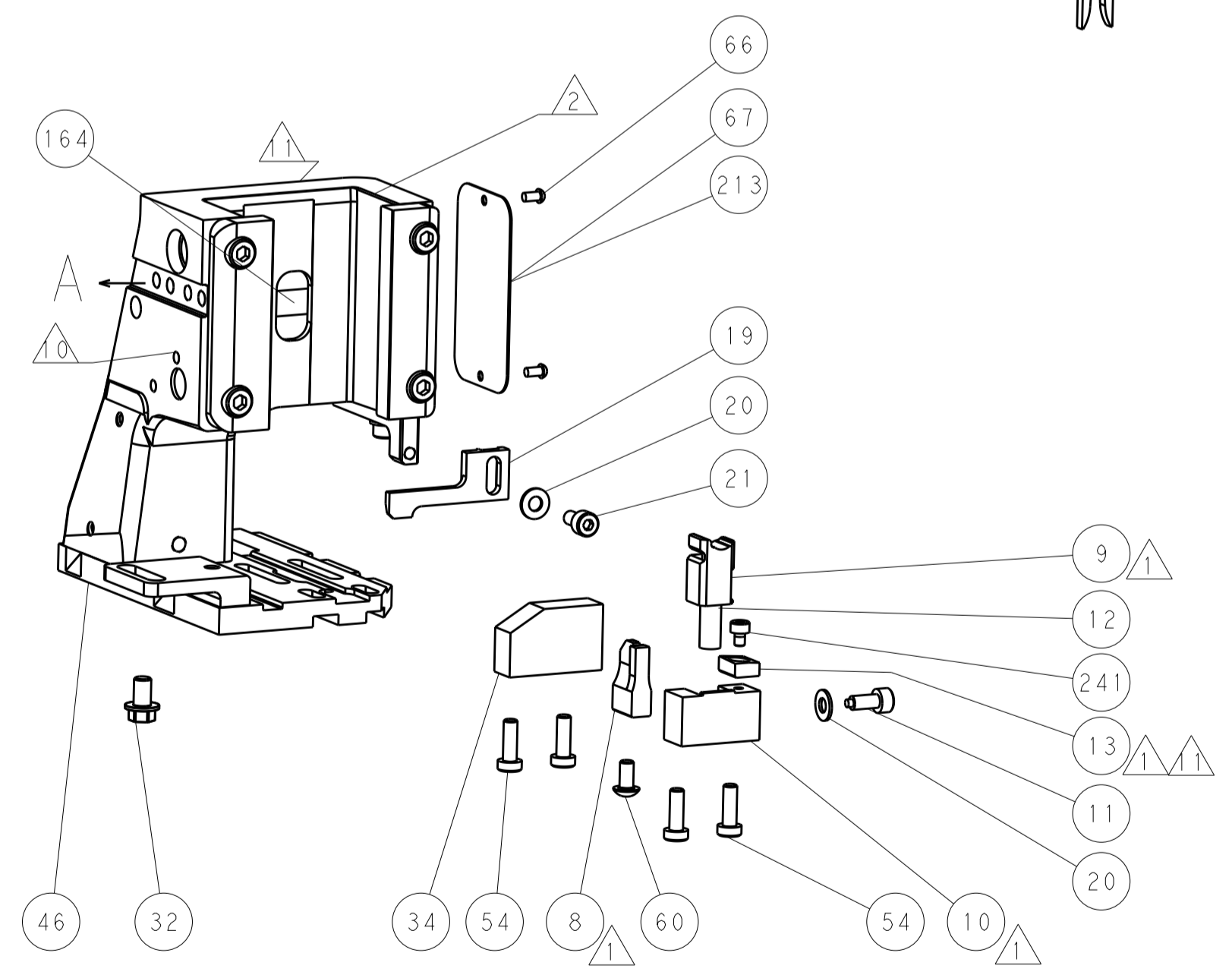
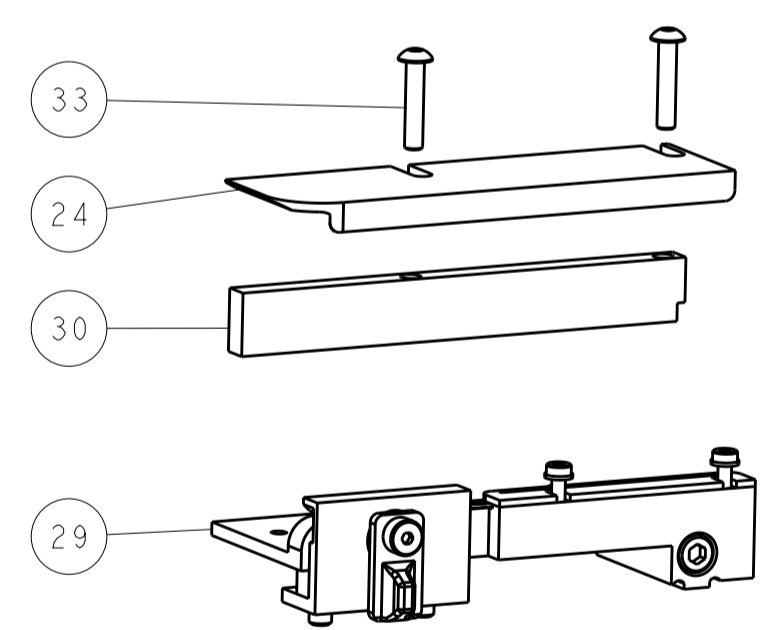

ITEM 30 LOCATED AT FRONT HOLES

FEED TRACK POSITION GUIDE BY INSULATION BARREL

ATLANTIC VERSION
 Shown on sheets 1 of 4 & 2 of 4
 (Pacific version shown on sheets 3 of 4 & 4 of 4)

DIMENSIONS:		TOLERANCES UNLESS OTHERWISE SPECIFIED:		DWG: J.HOU 10JULY2014		TE Connectivity	
mm	0 PLC ±0.5	1 PLC ±0.5	2 PLC ±0.13	3 PLC ±0.013	4 PLC ±0.001	APVD: Y.YIN 10JULY2014	Harrisburg, PA 17105-3608
MATERIAL:		FINISH:		NAME: Ocean Side Feed Applicator		RESTRICTED TO:	
				SIZE: A1		CAGE CODE: 00779	
				DRAWING NO: 2266410		SCALE: 1:2	
				SHEET: 2 of 4		REV: A	

PACIFIC VERSION TERMINATOR INTERFACE ADAPTER	PART NUMBER	REVISION	DESCRIPTION	FEED TYPE	APPLICATOR STYLE CONVERSION CHART						
					CONVERT TO	PART NUMBERS REQUIRED					
	2-2266410-1	A	FINE CRIMP HEIGHT ADJUST	MECHANICAL	PNEUMATIC FEED	2119950-1	1338685-1	5-18022-5	2119641-2	2119799-1	2063440-1
					SERVO LATCH PLATE	2119951-1	-	8-2266410-5	1901094-3	-	2168400-6 (QUANTITY 2)
					SMART APPLICATOR	2161326-1	-	8-2266410-4	-	-	-
	2-2266410-2	A	FINE CRIMP HEIGHT ADJUST	PNEUMATIC	MECHANICAL FEED	2119949-1	1338685-1	5-18022-5	2119653-2	-	-
					SERVO LATCH PLATE	2119951-1	-	8-2266410-5	1901094-3	-	2168400-6 (QUANTITY 2)
					SMART APPLICATOR	2161326-1	-	8-2266410-4	-	-	-
	2-2266410-5	A	FINE CRIMP HEIGHT ADJUST	SERVO LATCH PLATE ⁴	MECHANICAL FEED	2119949-1	1338685-1	5-18022-5	2119653-2	-	-
					PNEUMATIC FEED	2119950-1	1338685-1	5-18022-5	2119641-2	2119799-1	2063440-1
	2-2266410-7	A	FINE CRIMP HEIGHT ADJUST	NONE	-	-	-	-	-	-	-
	7-2266410-7	A	CRIMP TOOLING KIT	-	-	-	-	-	-	-	-

APPLICATOR DATA		
CRIMP	SIZE	TYPE
WIRE	2.03 mm [.080]	F
INSUL	4.57 mm [1.80]	O
APPLICATOR INSTRUCTIONS 408-10389		

TERMINAL DATA: HULANE TERMINAL		TE CRIMP SPECIFICATION	
TERMINAL NAME: TERMINAL			
WIRE STRIP LENGTH		INSULATION DIAMETER RANGE	
4.88-5.64 mm [1.92-.222 IN]		Ø 1.30mm MAX [1.051 IN] MAX	
TERMINAL APPLICATION SPECIFICATION	NONE	-	-
TERMINALS APPLIED			
TE TERMINAL	HULANE TERMINAL	TE SEAL	FANGYUAN SEAL
2113526-1	(6)619037PS7	2113500-1 2113527-1	7165-33541A 85901100215

WIRE SIZE	CRIMP HEIGHT mm [INCH]	CRIMP HEIGHT REFERENCE SETTING
1.25mm ²	1.32+/-0.05 [1.052+/-0.02]	5.1
1.00mm ²	1.22+/-0.05 [1.048+/-0.02]	6.2
0.85mm ²	1.15+/-0.05 [1.045+/-0.02]	7.1

- RECOMMENDED SPARE PARTS
- GREASE BEARING SURFACES LIGHTLY
- 3. LUBRICATE DAILY PER THE APPLICATOR INSTRUCTION SHEET SUPPLIED WITH THE APPLICATOR.
- APPLICATOR SPECIFIC DATA TO BE ENTERED INTO BLANK MEMORY CHIP AT ASSEMBLY. SEE BELOW FOR PART NUMBER:
 MECHANICAL FEED WITH "SMART APPLICATOR" CONVERSION: 8-2266410-4
 PNEUMATIC FEED WITH "SMART APPLICATOR" CONVERSION: 8-2266410-4
 SERVO FEED WITH "FINE CRIMP HEIGHT ADJUST": 8-2266410-5
- 5. ADJUSTMENT OF THE STRIPPER MAY BE REQUIRED WHEN MOVING THE APPLICATOR BETWEEN BENCH AND LEADMAKER APPLICATIONS.
- APPLY PART NUMBER 1-23419-5 LOCTITE TO THREADS OF ITEM 62.
 APPLY PART NUMBER 2-23419-6 LOCTITE TO THREADS OF ITEM 242.
- GREASE THREADS, GROOVE AND O-RING ON ITEMS 139 & 152.
- MAGNET MUST BE ORIENTED CORRECTLY IN ORDER TO PROPERLY ACTUATE THE COUNTER.
- CRIMP HEIGHT REFERENCE SETTING WAS THE SETTING USED WHEN THE APPLICATOR WAS QUALIFIED AT THE FACTORY. ADJUSTMENT MAY BE NECESSARY WHEN RUNNING APPLICATOR IN THE FIELD.
- SPARE FEED CAM STORAGE LOCATION REFER TO INSTRUCTION SHEET FOR ADDITIONAL INFORMATION.
- TO CONVERT THE APPLICATOR TO A NON-CARRIER CUTTING STYLE, REMOVE ITEM 13 AND ATTACH TO THE LOCATION ON BACK SIDE OF THE HOUSING. REFER TO INSTRUCTION SHEET FOR ADDITIONAL INFORMATION.
- THIS APPLICATOR APPLIES TERMINAL WITH A SEAL.
- APPLY TORQ-SEAL IN ALLEN SOCKET TO FILL HOLE AFTER FLAT HD HAS BEEN ADJUSTED TO CORRECT HEIGHT AT QUALIFICATION. APPLY #1-23419-5 LOC-TITE TO THREADS.

***WARNING**
 ON INSTALLATION, SET WIRE DISC, ITEM 40 TO LARGEST WIRE SIZE SETTING. USE OF SETTINGS BELOW MINIMUM REQUIRED CRIMP HEIGHT SETTING WILL CAUSE DAMAGE TO CRIMP TOOLING.

PACIFIC VERSION
 Shown on sheets 3 of 4 & 4 of 4
 (Atlantic version shown on sheets 1 of 4 & 2 of 4)

SET UP GAUGE	LOC	DIST	REVISIONS			
2119599-1	A	66	REV	DATE	BY	APPD
			-	SEE SHEET 1	-	-

-	1	1	1	1	2119782-1	FINE ADJUST HEAD ASM, PACIFIC STYLE	251
-	-	-	1	-	2119640-1	PUSH ROD, AIR FEED	250
-	-	-	1	-	2079988-1	BUSHING, LCH5-12, MISUMI	249
-	1	1	1	1	1-22279-3	SPRING, COMPRESSION	246
-	1	1	1	1	2119082-3	CAM, SNAIL, INSULATION ADJUSTMENT	244
-	1	1	1	1	2079764-1	WASHER, WAVE SPRING, CREST-TO-CREST	243
-	1	1	1	1	2119083-1	RETAINER, INSULATION DIAL	242
-	1	1	1	1	7-18023-7	SCR, SKT HD CAP M3 X 4.0	241
-	-	2	-	-	2168400-6	SHCS, LOW HEAD, RoHS, M5 X 16	240
-	-	-	-	1	2119580-1	MECHANICAL FEED ASSEMBLY	239
-	-	-	1	-	2063440-1	AIR FEED MODULE	238
-	-	-	1	-	2119740-2	TAG, IDENTIFICATION	213
-	-	1	-	-	1901094-3	SPACER, FEEDER	198
-	-	-	2	-	21045-3	RING, RETAIN, EXTERN, 3/16 CRESCENT	172
-	1	1	1	1	994969-1	MAGNET, RARE EARTH HIGH ENERGY	166
-	REF	REF	REF	REF	994970-2	COUNTER, MAGNETIC	164
-	-	-	1	-	240638-1	SPRING, FEED FINGER	163
-	1	1	1	1	8-21084-1	O-RING, .801 ID, .070 DIA. MAT.	152
-	-	-	1	-	2119641-2	FEED CAM, AIR FEED	151
-	1	1	1	1	2119798-2	DETENT PIN	145
-	1	1	1	1	2079383-8	SCR, BHSC, RoHS (M4 X 16)	144
-	4	4	4	4	2168400-5	SHCS, LOW HEAD, RoHS, M4 X 20	143
-	-	-	-	1	2119653-2	FEED CAM, POST FEED	142
-	1	1	1	1	1-2119656-0	APPLICATOR BASIC ASSEMBLY, SF	141
-	1	1	1	1	2119650-1	RAM, ASIAN STYLE, SIDE FEED	140
-	1	1	1	1	2119092-2	BOLT, ADJUSTMENT	139
-	-	-	1	-	3-23627-7	PIN, RETAIN, GRVD, 3/16 X .854	137
-	-	-	1	-	2119799-1	HOLDER, FEED FINGER, AF	136
-	-	REF	-	-	SEE NOTE 4	MEMORY CHIP, PROGRAMMED	135
-	-	1	-	-	1633743-1	SERVO FEED LATCH ASM	133
-	-	REF	-	-	2119944-1	FEED FINGER ASSEMBLY, SF	117
-	1	1	1	1	455888-5	SPACER, CRIMPER	82
-	1	1	1	1	2119956-1	DOCUMENTATION PACKAGE	71
-	1	-	1	1	2119740-1	TAG, IDENTIFICATION	67
-	2	2	2	2	2168078-1	SCREW, DRIVE, RH, RoHS, 2 x .188	66
-	1	1	1	1	2119793-1	LIMITER, ADJUSTMENT BOLT	63
-	3	3	3	3	992763-5	SCR, SET, SOC, CONE POINT, M3 x 4.0	62
-	-	-	1	1	5-18022-5	SCR, HEX HD CAP, M4 X 6.0	59
-	1	1	1	1	985575-3	SCR, FLT SKT HD CAP M3 X 10.0	57
-	-	-	1	1	1338685-1	PAWL, FEED	56
-	2	2	2	2	1-2168083-4	SCR, SKT HD CAP, RoHS, M4 X 5	53
-	-	-	1	2	18023-9	SCR, SKT HD CAP M4 X 6.0	49
-	-	-	-	1	2119652-1	FEED CAM, PRE FEED	48
-	1	1	1	1	2079383-7	SCR, BHSC, RoHS (M8 X 25)	41
-	1	1	1	1	2119645-1	DISC, NUMBERED FA WIRE ADJUSTMENT	40
-	1	1	1	1	2119957-1	APPLICATOR SHIM PACK	39
-	1	1	1	1	2119644-1	RAM WASHER, PRECISION	38
-	1	1	1	1	1752356-1	SUPPORT, TERMINAL	34
-	2	2	2	2	2079383-5	SCR, BHSC, RoHS (M4 X 20)	33
-	1	1	1	1	2161328-1	HEX HEAD, FLANGED, M5 x 8mm LONG	32
-	1	1	1	1	1320908-3	SPACER, STRIP GUIDE	30
-	1	1	1	1	2119959-1	ASSEMBLY, STRIP GUIDE	29
-	1	1	1	1	455888-3	SPACER, CRIMPER	28
-	1	1	1	1	1320928-2	STRIP GUIDE	24
-	1	1	1	1	2168083-2	SCR, SKT HD CAP, RoHS, M4 X 8.0	21
-	4	4	4	4	1-18028-2	WASHER, FLAT, REG M4	20
-	1	1	1	1	2119533-1	STRIPPER, SIDE FEED	19
-	1	1	1	1	5-690518-2	HOLD DOWN, TERMINAL	18
-	1	1	1	1	2119806-1	INSERT, SHEAR	13
-	1	1	1	1	3-22280-3	SPRING, COMPRESSION	12
-	1	1	1	1	1-356885-4	STOP, SHEAR	11
-	1	1	1	1	2119805-1	SHEAR HOLDER, FRONT	10
-	1	1	1	1	318707-1	FLOATING SHEAR, FRONT	9
-	1	1	1	1	3-1633920-1	ANVIL, COMBINATION	8
-	-	-	-	-	-	-	7
-	-	-	-	-	-	-	6
-	1	1	1	1	2119781-1	DEPRESSOR, SHEAR	5
-	1	1	1	1	2-238011-1	BLOCK, CRIMPER SPACER	4
-	1	1	1	1	6-2119784-0	CRIMPER, INSULATION O PREMIUM	3
-	1	1	1	1	1-455888-0	SPACER, CRIMPER	2
-	1	1	1	1	456405-8	CRIMPER, WIRE PREMIUM	1

DIMENSIONS:		TOLERANCES UNLESS OTHERWISE SPECIFIED:		OWN	CHK	APPD	REV	DATE	NAME	PRODUCT SPEC	APPLICATION SPEC	SIZE	CAGE CODE	DRAWING NO	RESTRICTED TO
mm	0 PLC ±.5	1 PLC ±0.5	2 PLC ±0.13	3 PLC ±0.013	4 PLC ±0.0013	ANGLES ±.1	FINISH								
MATERIAL		FINISH		WEIGHT		SCALE		SHEET		OF		REV		A	
						A1		00779		C=2266410		Customer Accessible Production Drawing		SCALE 1:2 SHEET 3 OF 4 REV A	

LOC	DIST	REVISIONS					
		P	LTN	DESCRIPTION	DATE	DWN	APVD
A	66	-	-	SEE SHEET 1	-	-	-

FEED TYPE MECHANICAL

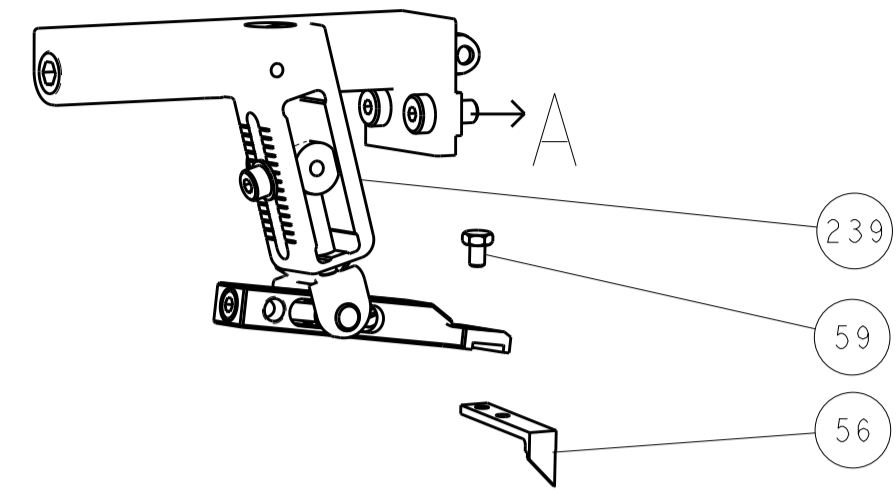

PNEUMATIC

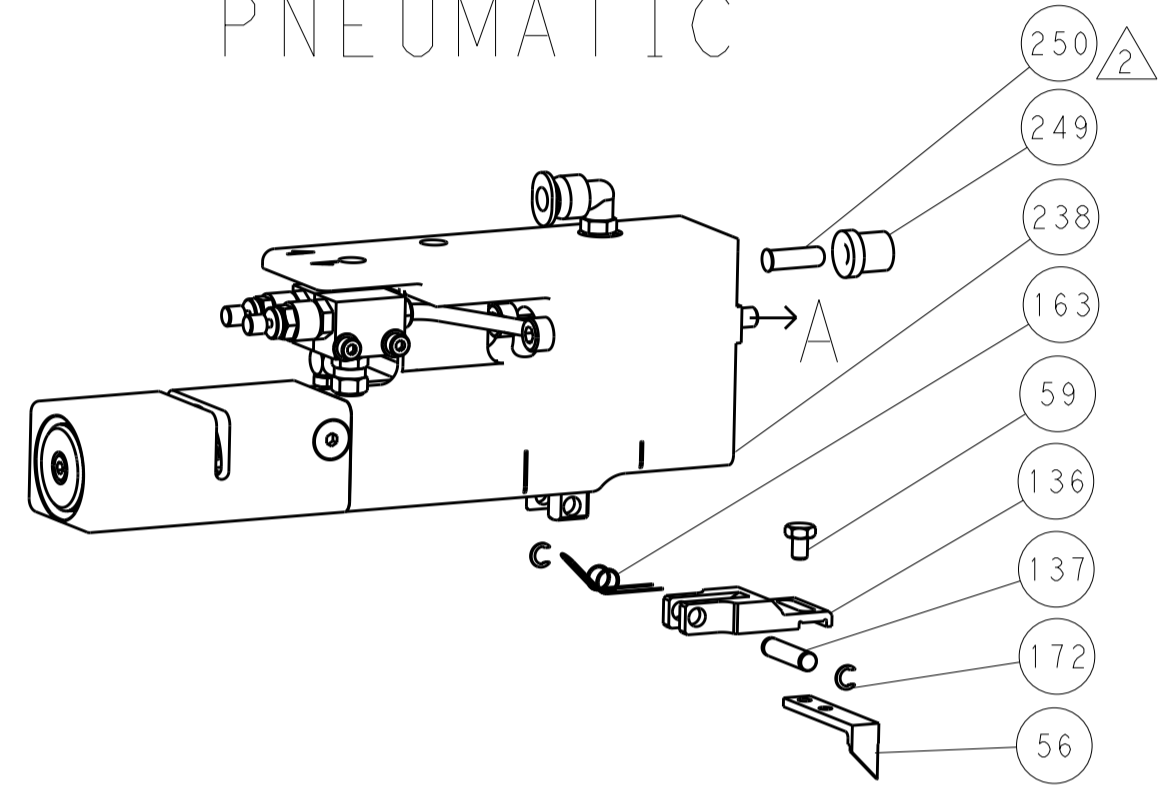

SERVO LATCH PLATE

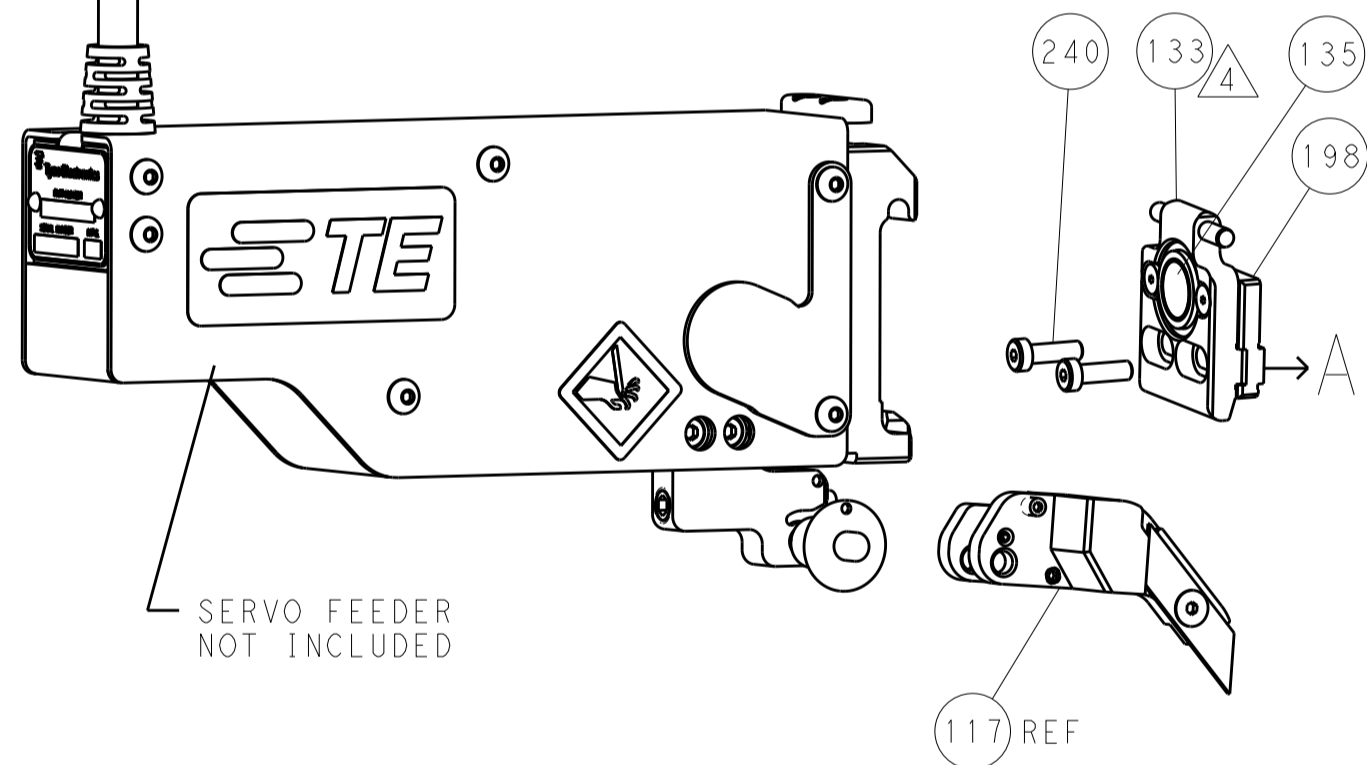

CAM POSITIONS

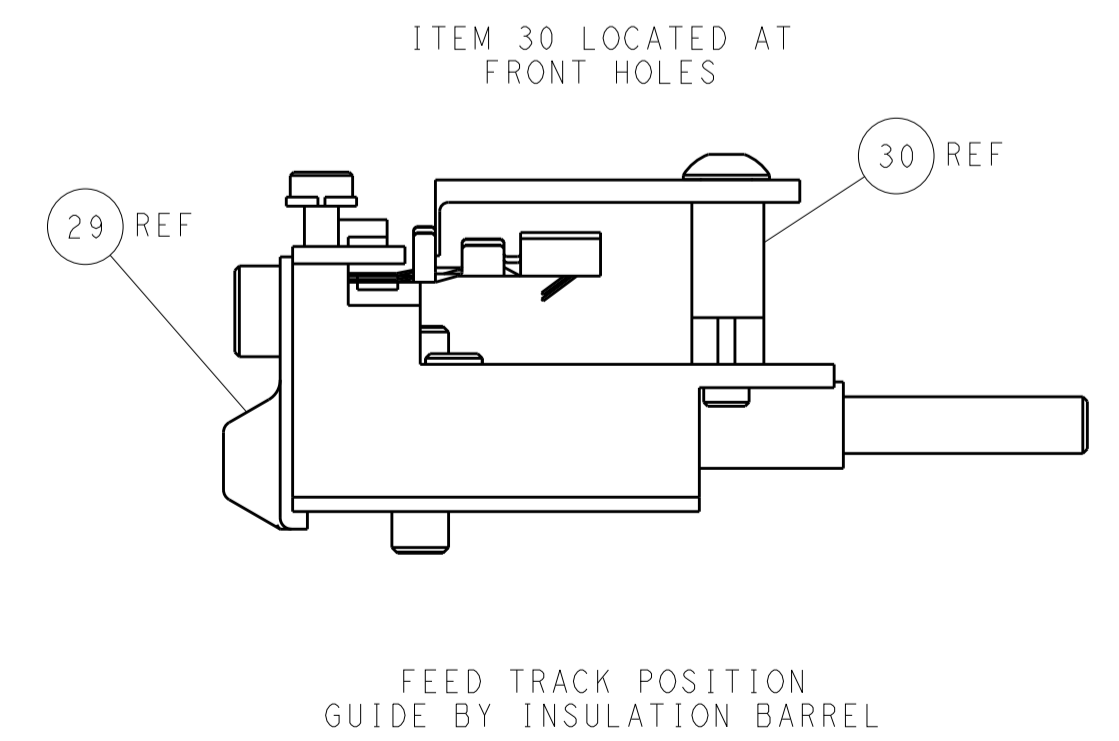
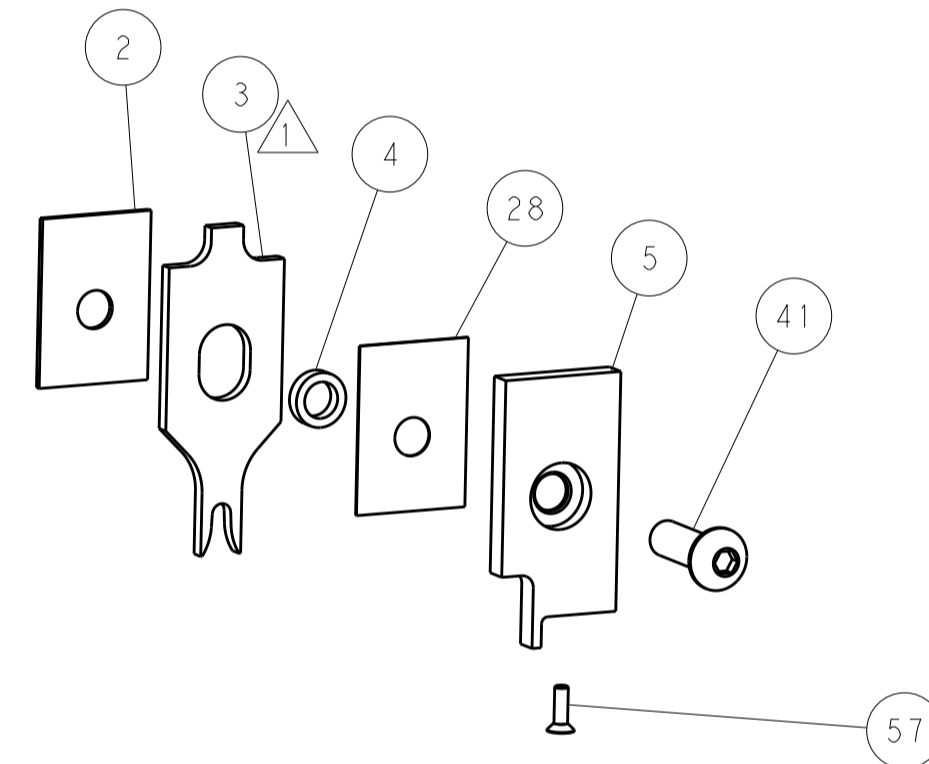
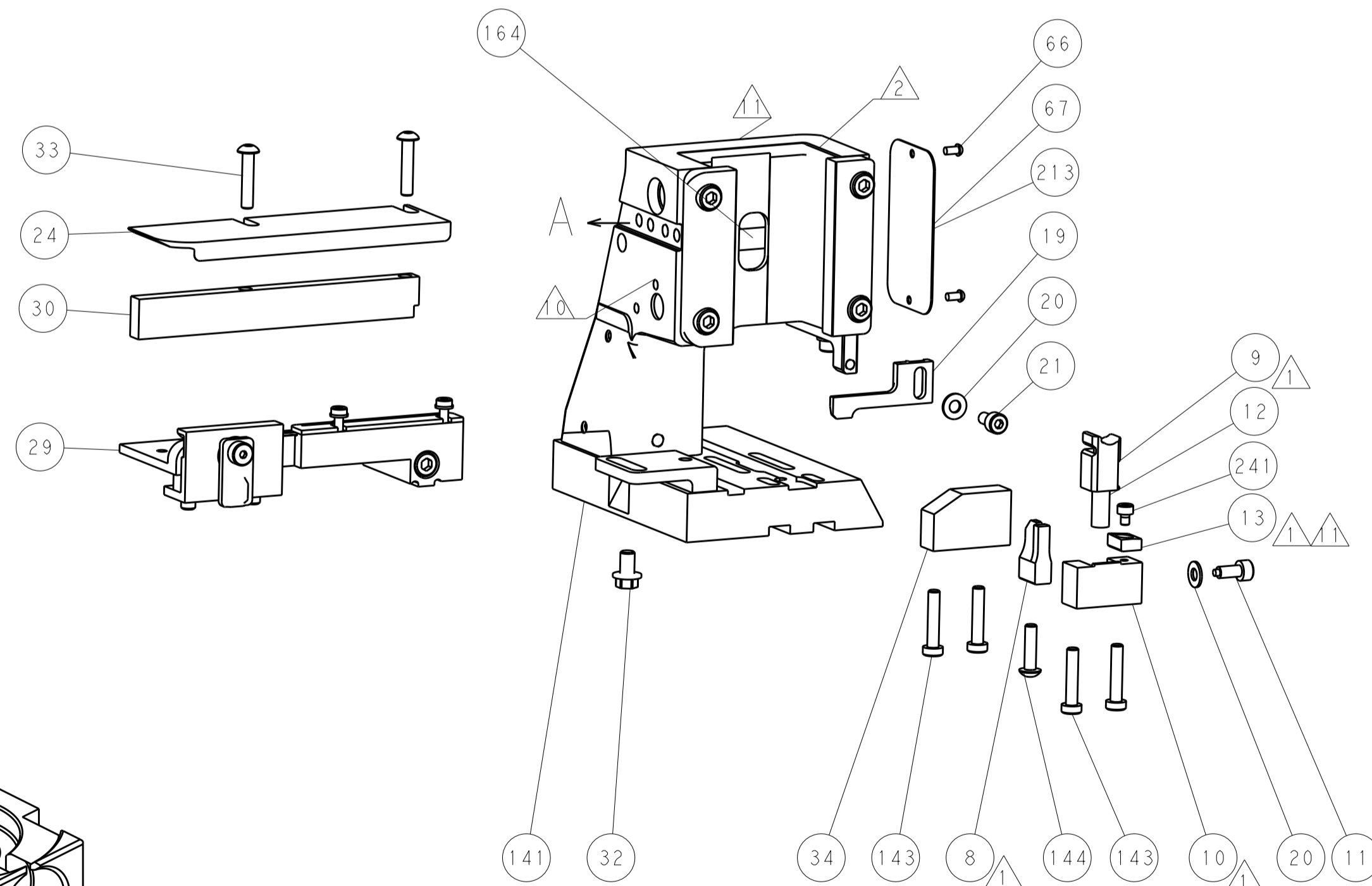
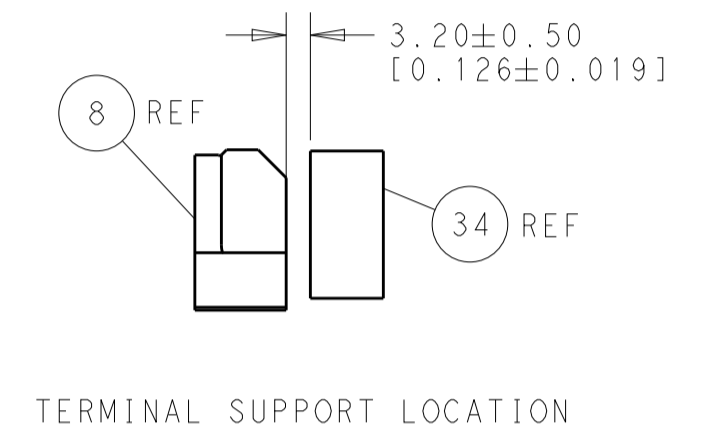
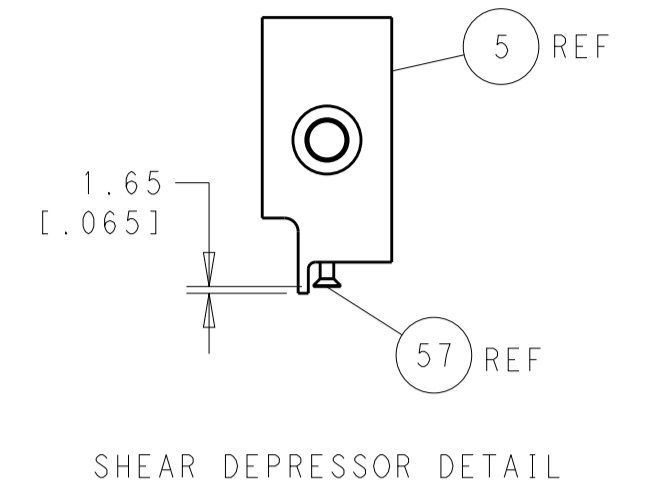
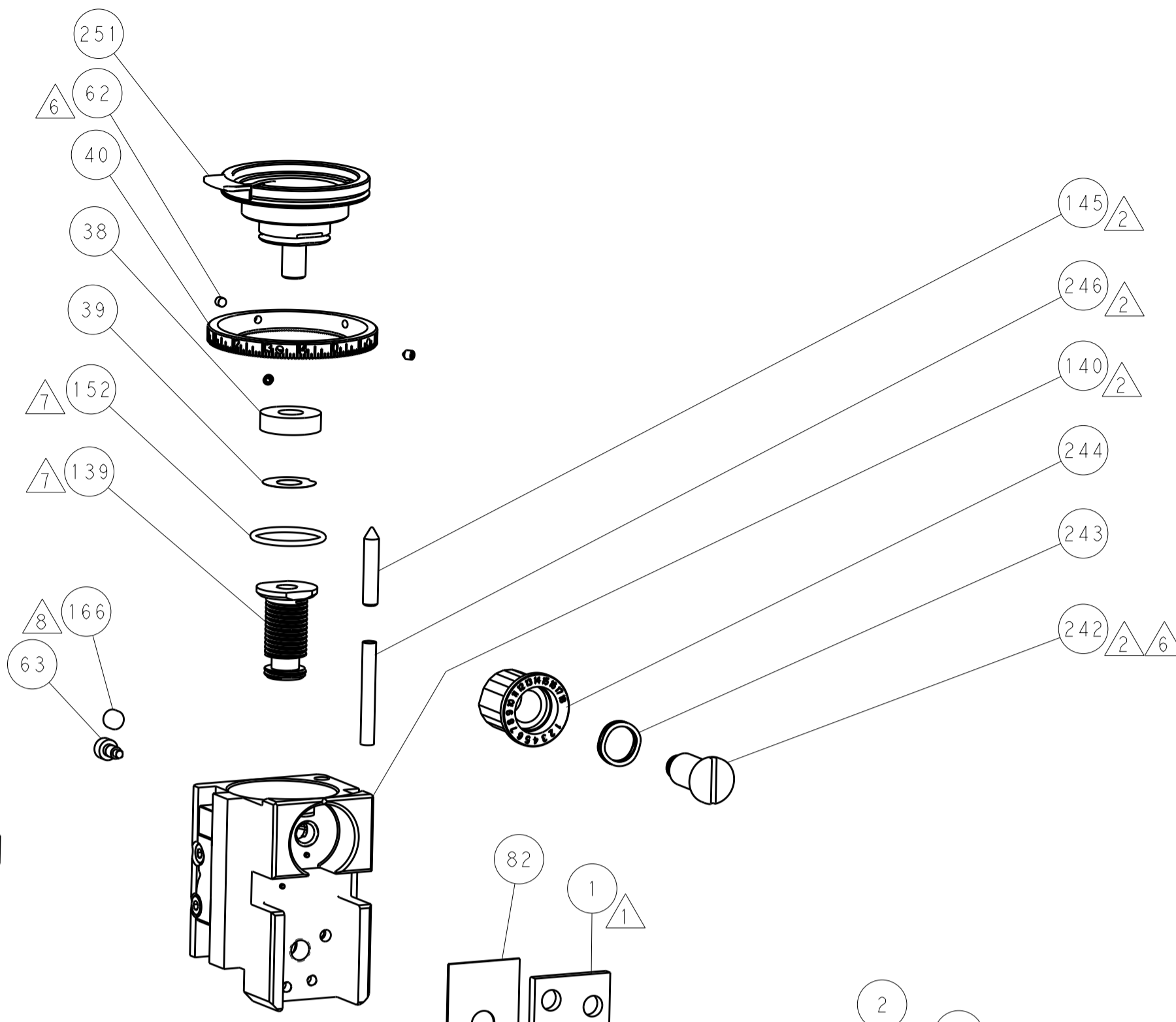
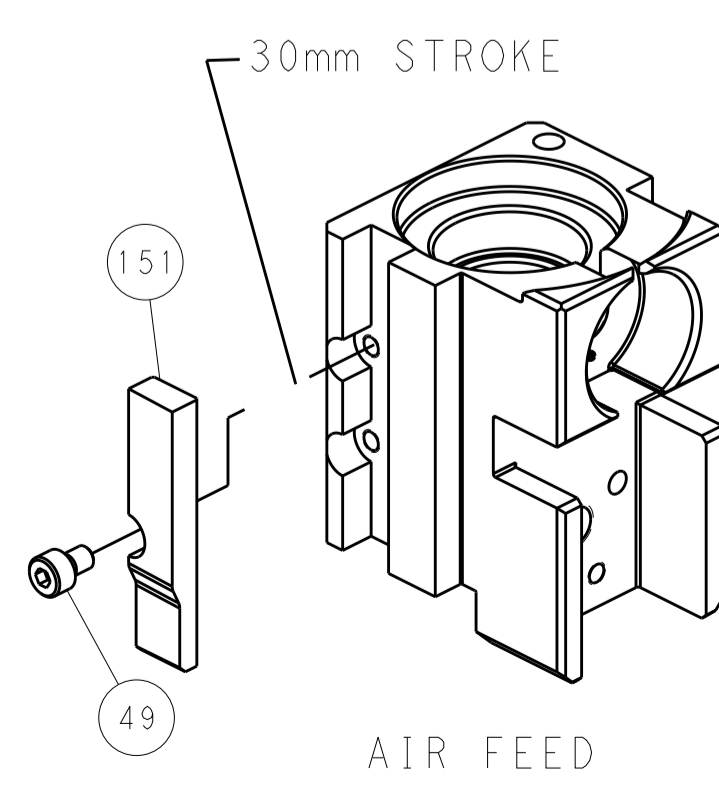
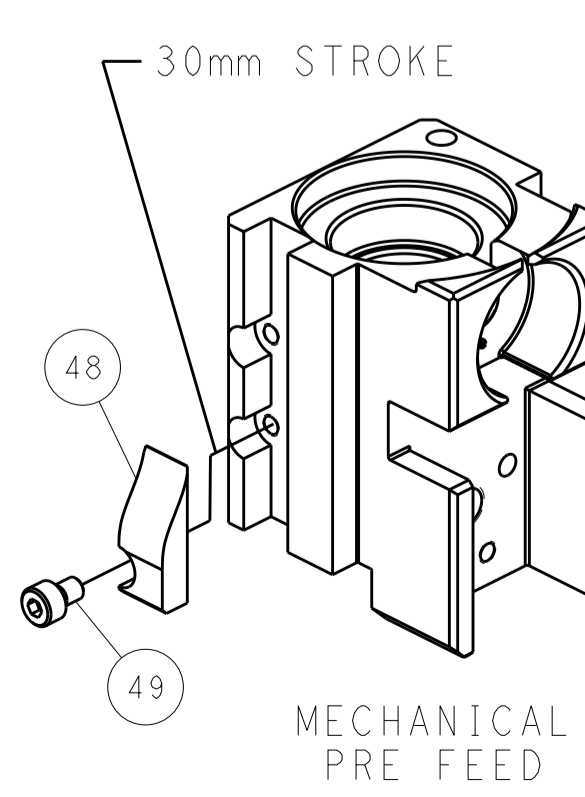
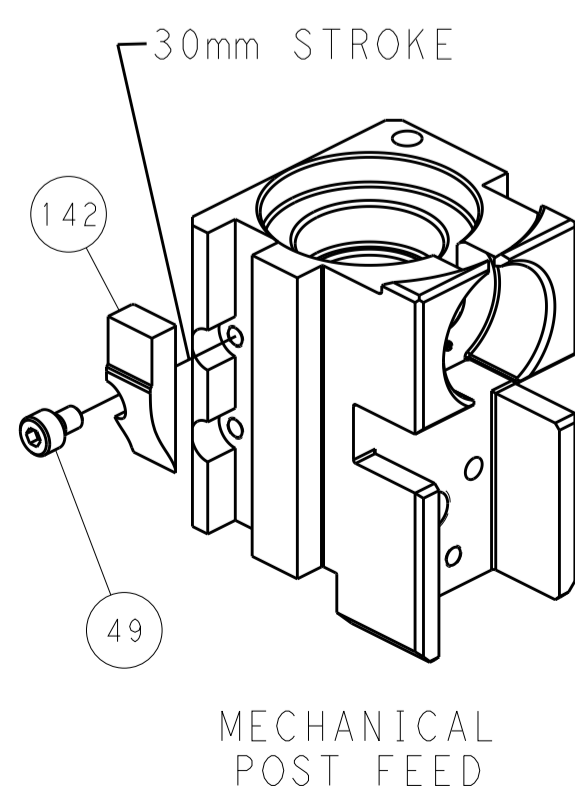

PACIFIC VERSION
 Shown on sheets 3 of 4 & 4 of 4
 (Atlantic version shown on sheets 1 of 4 & 2 of 4)

DIMENSIONS:		TOLERANCES UNLESS OTHERWISE SPECIFIED:		DWN: J.HOU TOJULY2014	TE Connectivity Harrisburg, PA 17105-3608
mm		0 PLC ±0.5		CHK: Y.YIN TOJULY2014	
		1 PLC ±0.13		APPV: H.GUO TOJULY2014	
MATERIAL:		FINISH:		PRODUCT SPEC:	NAME: Ocean Side Feed Applicator
				APPLICATION SPEC:	SIZE: CAGE CODE: DRAWING NO:
				WEIGHT:	A1 00779 C=2266410
				Customer Accessible Production Drawing	SCALE: 1:2 SHEET 4 OF 4 REV A